

PCT

WORLD INTELLECTUAL PROPERTY ORGANIZATION  
International Bureau

## INTERNATIONAL APPLICATION PUBLISHED UNDER THE PATENT COOPERATION TREATY (PCT)

(51) International Patent Classification <sup>6</sup> : C07H 21/04, 21/00, C12Q 1/68, C12P 19/34		A3	(11) International Publication Number: <b>WO 97/31256</b>
			(43) International Publication Date: 28 August 1997 (28.08.97)
(21) International Application Number: PCT/US97/01535		Apartment 5J, 420 E. 70th Street, New York, NY 10021 (US).	
(22) International Filing Date: 5 February 1997 (05.02.97)		(74) Agents: GOLDMAN, Michael, L. et al.; Nixon, Hargrave, Devans & Doyle L.L.P., Clinton Square, P.O. Box 1051, Rochester, NY 14603 (US).	
(30) Priority Data: 60/011,359 9 February 1996 (09.02.96) US		(81) Designated States: AL, AM, AT, AU, AZ, BA, BB, BG, BR, BY, CA, CH, CN, CU, CZ, DE, DK, EE, ES, FI, GB, GE, HU, IL, IS, JP, KE, KG, KP, KR, KZ, LC, LK, LR, LS, LT, LU, LV, MD, MG, MK, MN, MW, MX, NO, NZ, PL, PT, RO, RU, SD, SE, SG, SI, SK, TJ, TM, TR, TT, UA, UG, US, UZ, VN, ARIPO patent (KE, LS, MW, SD, SZ, UG), Eurasian patent (AM, AZ, BY, KG, KZ, MD, RU, TJ, TM), European patent (AT, BE, CH, DE, DK, ES, FI, FR, GB, GR, IE, IT, LU, MC, NL, PT, SE), OAPI patent (BF, BJ, CF, CG, CI, CM, GA, GN, ML, MR, NE, SN, TD, TG).	
(71) Applicants (for all designated States except US): CORNELL RESEARCH FOUNDATION, INC. [US/US]; Suite 105, 20 Thornwood Drive, Ithaca, NY 14850 (US). UNIVERSITY OF MINNESOTA [US/US]; Suite 201, 1100 Washington Avenue South, Minneapolis, MN 55415-1226 (US). LOUISIANA STATE UNIVERSITY [US/US]; Room 146A, Business and Technology Center, Baton Rouge, LA 70803 (US).		Published <i>With international search report. Before the expiration of the time limit for amending the claims and to be republished in the event of the receipt of amendments.</i>	
(72) Inventors; and (75) Inventors/Applicants (for US only): BARANY, Francis [US/US]; Apartment 12C, 450E. 63rd Street, New York, NY 10021 (US). BARANY, George [US/US]; 1813 Prior Avenue North, Falcon Heights, MN 55113 (US). HAMMER, Robert, P. [US/US]; 4967 Tulane Drive, Baton Rouge, LA 70808 (US). KEMPE, Maria [SE/US]; Apartment 1404, 401 South 1st Street, Minneapolis, MN 55401 (US). BLOK, Herman [NL/NL]; Westelijke Kanaalweg 53, NL-4424 BG Wemeldinge (NL). ZIRVI, Monib [US/US];		(88) Date of publication of the international search report: 25 September 1997 (25.09.97)	
(54) Title: DETECTION OF NUCLEIC ACID SEQUENCE DIFFERENCES USING THE LIGASE DETECTION REACTION WITH ADDRESSABLE ARRAYS			
(57) Abstract			
<p>The present invention describes a method for identifying one or more of a plurality of sequences differing by one or more single base changes, insertions, deletions, or translocations in a plurality of target nucleotide sequences. The method includes a ligation phase, a capture phase, and a detection phase. The ligation phase utilizes a ligation detection reaction between one oligonucleotide probe, which has a target sequence-specific portion and an addressable array-specific portion, and a second oligonucleotide probe, having a target sequence-specific portion and a detectable label. After the ligation phase, the capture phase is carried out by hybridizing the ligated oligonucleotide probes to a solid support with an array of immobilized capture oligonucleotides at least some of which are complementary to the addressable array-specific portion. Following completion of the capture phase, a detection phase is carried out to detect the labels of ligated oligonucleotide probes hybridized to the solid support. The ligation phase can be preceded by an amplification process. The present invention also relates to a kit for practicing this method, a method of forming arrays on solid supports, and the supports themselves.</p>			

**FOR THE PURPOSES OF INFORMATION ONLY**

Codes used to identify States party to the PCT on the front pages of pamphlets publishing international applications under the PCT.

AM	Armenia	GB	United Kingdom	MW	Malawi
AT	Austria	GE	Georgia	MX	Mexico
AU	Australia	GN	Guinea	NE	Niger
BB	Barbados	GR	Greece	NL	Netherlands
BE	Belgium	HU	Hungary	NO	Norway
BF	Burkina Faso	IE	Ireland	NZ	New Zealand
BG	Bulgaria	IT	Italy	PL	Poland
BJ	Benin	JP	Japan	PT	Portugal
BR	Brazil	KE	Kenya	RO	Romania
BY	Belarus	KG	Kyrgyzstan	RU	Russian Federation
CA	Canada	KP	Democratic People's Republic of Korea	SD	Sudan
CF	Central African Republic	KR	Republic of Korea	SE	Sweden
CG	Congo	KZ	Kazakhstan	SG	Singapore
CH	Switzerland	LJ	Liechtenstein	SI	Slovenia
CI	Côte d'Ivoire	LK	Sri Lanka	SK	Slovakia
CM	Cameroon	LR	Liberia	SN	Senegal
CN	China	LT	Lithuania	SZ	Swaziland
CS	Czechoslovakia	LU	Luxembourg	TD	Chad
CZ	Czech Republic	LV	Latvia	TG	Togo
DE	Germany	MC	Monaco	TJ	Tajikistan
DK	Denmark	MD	Republic of Moldova	TT	Trinidad and Tobago
EE	Estonia	MG	Madagascar	UA	Ukraine
ES	Spain	ML	Mali	UG	Uganda
FI	Finland	MN	Mongolia	US	United States of America
FR	France	MR	Mauritania	UZ	Uzbekistan
GA	Gabon			VN	Viet Nam

INTERNATIONAL SEARCH REPORT

International application No.  
PCT/US97/01535

**A. CLASSIFICATION OF SUBJECT MATTER**  
 IPC(6) : C07H 21/04, 21/00; C12Q 1/68; C12P 19/34  
 US CL : 435/6, 91.2; 536/24.3, 25.32  
 According to International Patent Classification (IPC) or to both national classification and IPC

**B. FIELDS SEARCHED**  
 Minimum documentation searched (classification system followed by classification symbols)  
 U.S. : 435/6, 91.2; 536/24.3, 25.32

Documentation searched other than minimum documentation to the extent that such documents are included in the fields searched

Electronic data base consulted during the international search (name of data base and, where practicable, search terms used)  
 Please See Extra Sheet.

**C. DOCUMENTS CONSIDERED TO BE RELEVANT**

Category*	Citation of document, with indication, where appropriate, of the relevant passages	Relevant to claim No.
Y	WO 92/10588 A1 (AFFYMAX TECHNOLOGIES N.V.) 25 June 1992, see entire document.	1-112 and 120-147
Y	WO 94/11530 A1 (TRUSTEES OF BOSTON UNIVERSITY) 26 May 1994, see entire document.	1-112 and 120-147
Y	WO 93/17126 A1 (THE PUBLIC HEALTH RESEARCH INSTITUTE OF THE CITY OF NEW YORK) 02 September 1993, see entire document.	1-112 and 120-147
Y,P	US 5,525,464 A(DRMANAC ET AL.) 11 June 1996, see entire document.	1-112 and 120-147
Y	US 5,412,087A(McGALL ET AL) 02 May 1995, see entire document, especially column 19, claims 2 and 3.	63, 67-69, 91-92, 97, 98, 122, 123, 128 and 129

Further documents are listed in the continuation of Box C.  See patent family annex.

* Special categories of cited documents:	*T	later document published after the international filing date or priority date and not in conflict with the application but cited to understand the principle or theory underlying the invention
*A* document defining the general state of the art which is not considered to be of particular relevance	*X*	document of particular relevance; the claimed invention cannot be considered novel or cannot be considered to involve an inventive step when the document is taken alone
*E* earlier document published on or after the international filing date	*Y*	document of particular relevance; the claimed invention cannot be considered to involve an inventive step when the document is combined with one or more other such documents, such combination being obvious to a person skilled in the art
*L* document which may throw doubts on priority claim(s) or which is cited to establish the publication date of another citation or other special reason (as specified)	*Z*	document member of the same patent family
*O* document referring to an oral disclosure, use, exhibition or other means		
*P* document published prior to the international filing date but later than the priority date claimed		

Date of the actual completion of the international search 16 JULY 1997	Date of mailing of the international search report 06 AUG 1997
---	---

Name and mailing address of the ISA/US Commissioner of Patents and Trademarks Box PCT Washington, D.C. 20231 Facsimile No. (703) 305-3230	Authorized officer <i>Joyce Tung</i> JOYCE TUNG Telephone No. (703) 308-0196
---	---

INTERNATIONAL SEARCH REPORT

International application No.  
PCT/US97/01535

Box I Observations where certain claims were found unsearchable (Continuation of item 1 of first sheet)

This international report has not been established in respect of certain claims under Article 17(2)(a) for the following reasons:

1.  Claims Nos.:  
because they relate to subject matter not required to be searched by this Authority, namely:
  
2.  Claims Nos.:  
because they relate to parts of the international application that do not comply with the prescribed requirements to such an extent that no meaningful international search can be carried out, specifically:
  
3.  Claims Nos.:  
because they are dependent claims and are not drafted in accordance with the second and third sentences of Rule 6.4(a).

Box II Observations where unity of invention is lacking (Continuation of item 2 of first sheet)

This International Searching Authority found multiple inventions in this international application, as follows:

Please See Extra Sheet.

1.  As all required additional search fees were timely paid by the applicant, this international search report covers all searchable claims.
2.  As all searchable claims could be searched without effort justifying an additional fee, this Authority did not invite payment of any additional fee.
3.  As only some of the required additional search fees were timely paid by the applicant, this international search report covers only those claims for which fees were paid, specifically claims Nos.:
  
4.  No required additional search fees were timely paid by the applicant. Consequently, this international search report is restricted to the invention first mentioned in the claims; it is covered by claims Nos.:  
1-112 and 120-147

- Remark on Protest  The additional search fees were accompanied by the applicant's protest.  
 No protest accompanied the payment of additional search fees.

INTERNATIONAL SEARCH REPORT

International application No.  
PCT/US97/01535

**B. FIELDS SEARCHED**

Electronic data bases consulted (Name of data base and where practicable terms used):

USPAT, MEDLINE, BIOSIS, CAPLUS

search terms: array, oligonucleotide probe, labels, ligase, amplification, solid support, capture probe, detect, hybridization

**BOX II. OBSERVATIONS WHERE UNITY OF INVENTION WAS LACKING**

This ISA found multiple inventions as follows:

This application contains the following inventions or groups of inventions which are not so linked as to form a single inventive concept under PCT Rule 13.1. In order for all inventions to be searched, the appropriate additional search fees must be paid.

Group I, claim(s) 1-112 and 120-147, drawn to a method for identifying one or more sequences differing by one or more single-base.

Group II, claim(s) 113-119, drawn to a device having chambers and valves.

The inventions listed as Groups I do not relate to a single inventive concept under PCT Rule 13.1 because, under PCT Rule 13.2, they lack the same or corresponding special technical features for the following reasons: Group I is drawn to a method for identifying sequences differing by one or more single-base which can be done by hand. Group II is drawn to a device which can be used for protein assay.

PCT

WORLD INTELLECTUAL PROPERTY ORGANIZATION  
International Bureau

## INTERNATIONAL APPLICATION PUBLISHED UNDER THE PATENT COOPERATION TREATY (PCT)

(51) International Patent Classification <sup>6</sup> : <b>G01N</b>	<b>A2</b>	(11) International Publication Number: <b>WO 97/31256</b> (43) International Publication Date: 28 August 1997 (28.08.97)
<p>(21) International Application Number: PCT/US97/01535</p> <p>(22) International Filing Date: 5 February 1997 (05.02.97)</p> <p>(30) Priority Data: 60/011,359 9 February 1996 (09.02.96) US</p> <p>(71) Applicants (for all designated States except US): CORNELL RESEARCH FOUNDATION, INC. [US/US]; Suite 105, 20 Thomwood Drive, Ithaca, NY 14850 (US). UNIVERSITY OF MINNESOTA [US/US]; Suite 201, 1100 Washington Avenue South, Minneapolis, MN 55415-1226 (US). LOUISIANA STATE UNIVERSITY [US/US]; Room 146A, Business and Technology Center, Baton Rouge, LA 70803 (US).</p> <p>(72) Inventors; and (75) Inventors/Applicants (for US only): BARANY, Francis [US/US]; Apartment 12C, 450E, 63rd Street, New York, NY 10021 (US). BARANY, George [US/US]; 1813 Prior Avenue North, Falcon Heights, MN 55113 (US). HAMMER, Robert, P. [US/US]; 4967 Tulane Drive, Baton Rouge, LA 70808 (US). KEMPE, Maria [SE/US]; Apartment 1404, 401 South 1st Street, Minneapolis, MN 55401 (US). BLOK, Herman [NL/NL]; Westelijke Kanaalweg 53, NL-4424 BG Wemeldinge (NL). ZIRVI, Monib [US/US];</p>	<p>Apartment 51, 420 E. 70th Street, New York, NY 10021 (US).</p> <p>(74) Agents: GOLDMAN, Michael, L. et al.; Nixon, Hargrave, Devans &amp; Doyle L.L.P., Clinton Square, P.O. Box 1051, Rochester, NY 14603 (US).</p> <p>(81) Designated States: AL, AM, AT, AU, AZ, BA, BB, BG, BR, BY, CA, CH, CN, CU, CZ, DE, DK, EE, ES, FI, GB, GE, HU, IL, IS, JP, KE, KG, KP, KR, KZ, LC, LK, LR, LS, LT, LU, LV, MD, MG, MK, MN, MW, MX, NO, NZ, PL, PT, RO, RU, SD, SE, SG, SI, SK, TJ, TM, TR, TT, UA, UG, US, UZ, VN, ARIPO patent (KE, LS, MW, SD, SZ, UG), Eurasian patent (AM, AZ, BY, KG, KZ, MD, RU, TJ, TM), European patent (AT, BE, CH, DE, DK, ES, FI, FR, GB, GR, IE, IT, LU, MC, NL, PT, SE), OAPI patent (BF, BJ, CF, CG, CI, CM, GA, GN, ML, MR, NE, SN, TD, TG).</p> <p><b>Published</b> <i>Without international search report and to be republished upon receipt of that report.</i></p>	
<p>(54) Title: DETECTION OF NUCLEIC ACID SEQUENCE DIFFERENCES USING THE LIGASE DETECTION REACTION WITH ADDRESSABLE ARRAYS</p> <p>(57) Abstract</p> <p>The present invention describes a method for identifying one or more of a plurality of sequences differing by one or more single base changes, insertions, deletions, or translocations in a plurality of target nucleotide sequences. The method includes a ligation phase, a capture phase, and a detection phase. The ligation phase utilizes a ligation detection reaction between one oligonucleotide probe, which has a target sequence-specific portion and an addressable array-specific portion, and a second oligonucleotide probe, having a target sequence-specific portion and a detectable label. After the ligation phase, the capture phase is carried out by hybridizing the ligated oligonucleotide probes to a solid support with an array of immobilized capture oligonucleotides at least some of which are complementary to the addressable array-specific portion. Following completion of the capture phase, a detection phase is carried out to detect the labels of ligated oligonucleotide probes hybridized to the solid support. The ligation phase can be preceded by an amplification process. The present invention also relates to a kit for practicing this method, a method of forming arrays on solid supports, and the supports themselves.</p>		

**FOR THE PURPOSES OF INFORMATION ONLY**

Codes used to identify States party to the PCT on the front pages of pamphlets publishing international applications under the PCT.

AM	Armenia	GB	United Kingdom	MW	Malawi
AT	Austria	GE	Georgia	MX	Mexico
AU	Australia	GN	Guinea	NE	Niger
BB	Barbados	GR	Greece	NL	Netherlands
BE	Belgium	HU	Hungary	NO	Norway
BF	Burkina Faso	IE	Ireland	NZ	New Zealand
BG	Bulgaria	IT	Italy	PL	Poland
BJ	Benin	JP	Japan	PT	Portugal
BR	Brazil	KE	Kenya	RO	Romania
BY	Belarus	KG	Kyrgyzstan	RU	Russian Federation
CA	Canada	KP	Democratic People's Republic of Korea	SD	Sudan
CF	Central African Republic	KR	Republic of Korea	SE	Sweden
CG	Congo	KZ	Kazakhstan	SG	Singapore
CH	Switzerland	LI	Liechtenstein	SI	Slovenia
CI	Côte d'Ivoire	LK	Sri Lanka	SK	Slovakia
CM	Cameroon	LR	Liberia	SN	Senegal
CN	China	LT	Lithuania	SZ	Swaziland
CS	Czechoslovakia	LU	Luxembourg	TD	Chad
CZ	Czech Republic	LV	Latvia	TG	Togo
DE	Germany	MC	Monaco	TJ	Tajikistan
DK	Denmark	MD	Republic of Moldova	TT	Trinidad and Tobago
EE	Estonia	MG	Madagascar	UA	Ukraine
ES	Spain	ML	Mali	UG	Uganda
FI	Finland	MN	Mongolia	US	United States of America
FR	France	MR	Mauritania	UZ	Uzbekistan
GA	Gabon			VN	Viet Nam

## DETECTION OF NUCLEIC ACID SEQUENCE DIFFERENCES USING THE LIGASE DETECTION REACTION WITH ADDRESSABLE ARRAYS

This application claims the benefit of U.S. Provisional Patent Application Serial  
5 No. 60/011,359, filed February 9, 1996.

This invention was developed with government funding under National Institutes  
of Health Grant Nos. GM-41337-06, GM-43552-05, GM-42722-07, and GM-51628-02.  
The U.S. Government may have certain rights.

10

### FIELD OF THE INVENTION

The present invention relates to the detection of nucleic acid sequence differences  
in nucleic acids using a ligation phase, a capture phase, and a detection phase. The  
ligation phase utilizes a ligation detection reaction between one oligonucleotide probe  
15 which has a target sequence-specific portion and an addressable array-specific portion and  
a second oligonucleotide probe having a target sequence-specific portion and a detectable  
label. The capture phase involves hybridizing the ligated oligonucleotide probes to a solid  
support with an array of immobilized capture oligonucleotides at least some of which are  
complementary to the addressable array-specific portion. The labels of ligated  
20 oligonucleotide probes hybridized to the solid support are detected during the detection  
phase.

### BACKGROUND OF THE INVENTION

#### 25 Detection of Sequence Differences

Large-scale multiplex analysis of highly polymorphic loci is needed for practical  
identification of individuals, e.g., for paternity testing and in forensic science (Reynolds et  
al., Anal. Chem., 63:2-15 (1991)), for organ-transplant donor-recipient matching (Buyse et  
30 al., Tissue Antigens, 41:1-14 (1993) and Gyllensten et al., PCR Meth. Appl., 1:91-98  
(1991)), for genetic disease diagnosis, prognosis, and pre-natal counseling (Chamberlain et  
al., Nucleic Acids Res., 16:11141-11156 (1988) and L. C. Tsui, Human Mutat., 1:197-203  
(1992)), and the study of oncogenic mutations (Hollstein et al., Science, 253:49-53  
(1991)). In addition, the cost-effectiveness of infectious disease diagnosis by nucleic acid  
35 analysis varies directly with the multiplex scale in panel testing. Many of these  
applications depend on the discrimination of single-base differences at a multiplicity of  
sometimes closely spaced loci.

A variety of DNA hybridization techniques are available for detecting the presence  
of one or more selected polynucleotide sequences in a sample containing a large number  
40 of sequence regions. In a simple method, which relies on fragment capture and labeling, a  
fragment containing a selected sequence is captured by hybridization to an immobilized



probe. The captured fragment can be labeled by hybridization to a second probe which contains a detectable reporter moiety.

Another widely used method is Southern blotting. In this method, a mixture of DNA fragments in a sample are fractionated by gel electrophoresis, then fixed on a nitrocellulose filter. By reacting the filter with one or more labeled probes under hybridization conditions, the presence of bands containing the probe sequence can be identified. The method is especially useful for identifying fragments in a restriction-enzyme DNA digest which contain a given probe sequence, and for analyzing restriction-fragment length polymorphisms ("RFLPs").

Another approach to detecting the presence of a given sequence or sequences in a polynucleotide sample involves selective amplification of the sequence(s) by polymerase chain reaction. U.S. Patent No. 4,683,202 to Mullis, et al. and R.K. Saiki, et al., Science 230:1350 (1985). In this method, primers complementary to opposite end portions of the selected sequence(s) are used to promote, in conjunction with thermal cycling, successive rounds of primer-initiated replication. The amplified sequence may be readily identified by a variety of techniques. This approach is particularly useful for detecting the presence of low-copy sequences in a polynucleotide-containing sample, e.g., for detecting pathogen sequences in a body-fluid sample.

More recently, methods of identifying known target sequences by probe ligation methods have been reported. U.S. Patent No. 4,883,750 to N.M. Whiteley, et al., D.Y. Wu, et al., Genomics 4:560 (1989), U. Landegren, et al., Science 241:1077 (1988), and E. Winn-Deen, et al., Clin. Chem. 37:1522 (1991). In one approach, known as oligonucleotide ligation assay ("OLA"), two probes or probe elements which span a target region of interest are hybridized with the target region. Where the probe elements match (basepair with) adjacent target bases at the confronting ends of the probe elements, the two elements can be joined by ligation, e.g., by treatment with ligase. The ligated probe element is then assayed, evidencing the presence of the target sequence.

In a modification of this approach, the ligated probe elements act as a template for a pair of complementary probe elements. With continued cycles of denaturation, hybridization, and ligation in the presence of the two complementary pairs of probe elements, the target sequence is amplified geometrically, i.e., exponentially allowing very small amounts of target sequence to be detected and/or amplified. This approach is referred to as ligase chain reaction ("LCR"). F. Barany, "Genetic Disease Detection and DNA Amplification Using Cloned Thermostable Ligase," Proc. Nat'l Acad. Sci. USA. 88:189-93 (1991) and F. Barany, "The Ligase Chain Reaction (LCR) in a PCR World." PCR Methods and Applications, 1:5-16 (1991).

Another scheme for multiplex detection of nucleic acid sequence differences is disclosed in U.S. Patent No. 5,470,705 to Grossman et. al. where sequence-specific probes, having a detectable label and a distinctive ratio of charge/translational frictional drag, can be hybridized to a target and ligated together. This technique was used in

Grossman, et. al., "High-density Multiplex Detection of Nucleic Acid Sequences: Oligonucleotide Ligation Assay and Sequence-coded Separation," Nucl. Acids Res. 22(21):4527-34 (1994) for the large scale multiplex analysis of the cystic fibrosis transmembrane regulator gene.

5       Jou, et. al., "Deletion Detection in Dystrophin Gene by Multiplex Gap Ligase Chain Reaction and Immunochromatographic Strip Technology," Human Mutation 5:86-93 (1995) relates to the use of a so called "gap ligase chain reaction" process to amplify simultaneously selected regions of multiple exons with the amplified products being read on an immunochromatographic strip having antibodies specific to the different haptens on  
10 the probes for each exon.

      There is a growing need, e.g., in the field of genetic screening, for methods useful in detecting the presence or absence of each of a large number of sequences in a target polynucleotide. For example, as many as 400 different mutations have been associated with cystic fibrosis. In screening for genetic predisposition to this disease, it is optimal to  
15 test all of the possible different gene sequence mutations in the subject's genomic DNA, in order to make a positive identification of "cystic fibrosis". It would be ideal to test for the presence or absence of all of the possible mutation sites in a single assay. However, the prior-art methods described above are not readily adaptable for use in detecting multiple selected sequences in a convenient, automated single-assay format.

20       Solid-phase hybridization assays require multiple liquid-handling steps, and some incubation and wash temperatures must be carefully controlled to keep the stringency needed for single-nucleotide mismatch discrimination. Multiplexing of this approach has proven difficult as optimal hybridization conditions vary greatly among probe sequences.

      Allele-specific PCR products generally have the same size, and a given  
25 amplification tube is scored by the presence or absence of the product band in the gel lane associated with each reaction tube. Gibbs et al., Nucleic Acids Res. 17:2437-2448 (1989). This approach requires splitting the test sample among multiple reaction tubes with different primer combinations, multiplying assay cost. PCR has also discriminated  
30 alleles by attaching different fluorescent dyes to competing allelic primers in a single reaction tube (F.F. Chehab, et al., Proc. Natl. Acad. Sci. USA, 86:9178-9182 (1989)), but this route to multiplex analysis is limited in scale by the relatively few dyes which can be spectrally resolved in an economical manner with existing instrumentation and dye chemistry. The incorporation of bases modified with bulky side chains can be used to differentiate allelic PCR products by their electrophoretic mobility, but this method is  
35 limited by the successful incorporation of these modified bases by polymerase, and by the ability of electrophoresis to resolve relatively large PCR products which differ in size by only one of these groups. Livak et al., Nucleic Acids Res., 20:4831-4837 (1989). Each PCR product is used to look for only a single mutation, making multiplexing difficult.

      Ligation of allele-specific probes generally has used solid-phase capture (U.  
40 Landegren et al., Science, 241:1077-1080 (1988); Nickerson et al., Proc. Natl. Acad. Sci.

USA, 87:8923-8927 (1990)) or size-dependent separation (D.Y. Wu, et al., Genomics, 4:560-569 (1989) and F. Barany, Proc. Natl. Acad. Sci., 88:189-193 (1991)) to resolve the allelic signals, the latter method being limited in multiplex scale by the narrow size range of ligation probes. The gap ligase chain reaction process requires an additional step --  
5 polymerase extension. The use of probes with distinctive ratios of charge/translational frictional drag technique to a more complex multiplex will either require longer electrophoresis times or the use of an alternate form of detection.

The need thus remains for a rapid single assay format to detect the presence or absence of multiple selected sequences in a polynucleotide sample.

10

#### Use of Oligonucleotide Arrays for Nucleic Acid Analysis

Ordered arrays of oligonucleotides immobilized on a solid support have been proposed for sequencing, sorting, isolating, and manipulating DNA. It has been  
15 recognized that hybridization of a cloned single-stranded DNA molecule to all possible oligonucleotide probes of a given length can theoretically identify the corresponding complementary DNA segments present in the molecule. In such an array, each oligonucleotide probe is immobilized on a solid support at a different predetermined position. All the oligonucleotide segments in a DNA molecule can be surveyed with such  
20 an array.

One example of a procedure for sequencing DNA molecules using arrays of oligonucleotides is disclosed in U.S. Patent No. 5,202,231 to Drmanac, et. al. This involves application of target DNA to a solid support to which a plurality of oligonucleotides are attached. Sequences are read by hybridization of segments of the  
25 target DNA to the oligonucleotides and assembly of overlapping segments of hybridized oligonucleotides. The array utilizes all possible oligonucleotides of a certain length between 11 and 20 nucleotides, but there is little information about how this array is constructed. See also A. B. Chetverin, et. al., "Sequencing of Pools of Nucleic Acids on Oligonucleotide Arrays," BioSystems 30: 215-31 (1993); WO 92/16655 to Khrapko et. al.;  
30 Kuznetsova. et. al., "DNA Sequencing by Hybridization with Oligonucleotides Immobilized in Gel. Chemical Ligation as a Method of Expanding the Prospects for the Method," Mol. Biol. 28(20): 290-99(1994); M.A. Livits, et. al., "Dissociation of Duplexes Formed by Hybridization of DNA with Gel-Immobilized Oligonucleotides," J. Biomolec. Struct. & Dynam. 11(4): 783-812 (1994).

35 WO 89/10977 to Southern discloses the use of a support carrying an array of oligonucleotides capable of undergoing a hybridization reaction for use in analyzing a nucleic acid sample for known point mutations, genomic fingerprinting, linkage analysis, and sequence determination. The matrix is formed by laying nucleotide bases in a selected pattern on the support. This reference indicates that a hydroxyl linker group can be

applied to the support with the oligonucleotides being assembled by a pen plotter or by masking.

WO 94/11530 to Cantor also relates to the use of an oligonucleotide array to carry out a process of sequencing by hybridization. The oligonucleotides are duplexes having  
5 overhanging ends to which target nucleic acids bind and are then ligated to the non-overhanging portion of the duplex. The array is constructed by using streptavidin-coated filter paper which captures biotinylated oligonucleotides assembled before attachment.

WO 93/17126 to Chetverin uses sectioned, binary oligonucleotide arrays to sort and survey nucleic acids. These arrays have a constant nucleotide sequence attached to an  
10 adjacent variable nucleotide sequence, both bound to a solid support by a covalent linking moiety. The constant nucleotide sequence has a priming region to permit amplification by PCR of hybridized strands. Sorting is then carried out by hybridization to the variable region. Sequencing, isolating, sorting, and manipulating fragmented nucleic acids on these binary arrays are also disclosed. In one embodiment with enhanced sensitivity, the  
15 immobilized oligonucleotide has a shorter complementary region hybridized to it, leaving part of the oligonucleotide uncovered. The array is then subjected to hybridization conditions so that a complementary nucleic acid anneals to the immobilized oligonucleotide. DNA ligase is then used to join the shorter complementary region and the complementary nucleic acid on the array. There is little disclosure of how to prepare  
20 the arrays of oligonucleotides.

WO 92/10588 to Fodor et. al., discloses a process for sequencing, fingerprinting, and mapping nucleic acids by hybridization to an array of oligonucleotides. The array of oligonucleotides is prepared by a very large scale immobilized polymer synthesis which permits the synthesis of large, different oligonucleotides. In this procedure, the substrate  
25 surface is functionalized and provided with a linker group by which oligonucleotides are assembled on the substrate. The regions where oligonucleotides are attached have protective groups (on the substrate or individual nucleotide subunits) which are selectively activated. Generally, this involves imaging the array with light using a mask of varying configuration so that areas exposed are deprotected. Areas which have been deprotected  
30 undergo a chemical reaction with a protected nucleotide to extend the oligonucleotide sequence where imaged. A binary masking strategy can be used to build two or more arrays at a given time. Detection involves positional localization of the region where hybridization has taken place. See also U.S. Patent Nos. 5,324,633 and 5,424,186 to Fodor et. al., U.S. Patent Nos. 5,143,854 and 5,405,783 to Pirrung, et. al., WO 90/15070 to  
35 Pirrung, et. al., A. C. Pease, et. al., "Light-generated Oligonucleotide Arrays for Rapid DNA Sequence Analysis", *Proc. Natl. Acad. Sci USA* 91: 5022-26 (1994). K. L. Beattie, et. al., "Advances in Genosensor Research," *Clin. Chem.* 41(5): 700-09 (1995) discloses attachment of previously assembled oligonucleotide probes to a solid support.

There are many drawbacks to the procedures for sequencing by hybridization to  
40 such arrays. Firstly, a very large number of oligonucleotides must be synthesized.

Secondly, there is poor discrimination between correctly hybridized, properly matched duplexes and those which are mismatched. Finally, certain oligonucleotides will be difficult to hybridize to under standard conditions, with such oligonucleotides being capable of identification only through extensive hybridization studies.

5 The present invention is directed toward overcoming these deficiencies in the art.

#### SUMMARY OF THE INVENTION

10 The present invention relates to a method for identifying one or more of a plurality of sequences differing by one or more single base changes, insertions, deletions, or translocations in a plurality of target nucleotide sequences. The method includes a ligation phase, a capture phase, and a detection phase.

The ligation phase requires providing a sample potentially containing one or more nucleotide sequences with a plurality of sequence differences. A plurality of  
15 oligonucleotide sets are utilized in this phase. Each set includes a first oligonucleotide probe, having a target-specific portion and an addressable array-specific portion, and a second oligonucleotide probe, having a target-specific portion and a detectable reporter label. The first and second oligonucleotide probes in a particular set are suitable for ligation together when hybridized adjacent to one another on a corresponding target  
20 nucleotide sequence. However, the first and second oligonucleotide probes have a mismatch which interferes with such ligation when hybridized to another nucleotide sequence present in the sample. A ligase is also utilized. The sample, the plurality of oligonucleotide probe sets, and the ligase are blended to form a mixture. The mixture is subjected to one or more ligase detection reaction cycles comprising a denaturation  
25 treatment and a hybridization treatment. The denaturation treatment involves separating any hybridized oligonucleotides from the target nucleotide sequences. The hybridization treatment involves hybridizing the oligonucleotide probe sets at adjacent positions in a base-specific manner to their respective target nucleotide sequences, if present in the sample, and ligating them to one another to form a ligated product sequence containing (a)  
30 the addressable array-specific portion, (b) the target-specific portions connected together, and (c) the detectable reporter label. The oligonucleotide probe sets may hybridize to nucleotide sequences in the sample other than their respective target nucleotide sequences but do not ligate together due to a presence of one or more mismatches and individually separate during denaturation treatment.

35 The next phase of the process is the capture phase. This phase involves providing a solid support with capture oligonucleotides immobilized at particular sites. The capture oligonucleotides are complementary to the addressable array-specific portions. The mixture, after being subjected to the ligation phase, is contacted with the solid support under conditions effective to hybridize the addressable array-specific portions to the  
40 capture oligonucleotides in a base-specific manner. As a result, the addressable array-

specific portions are captured on the solid support at the site with the complementary capture oligonucleotides.

After the capture phase is the detection phase. During this portion of the process, the reporter labels of the ligated product sequences are captured on the solid support at particular sites. When the presence of the reporter label bound to the solid support is detected, the respective presence of one or more nucleotide sequences in the sample is indicated.

The present invention also relates to a kit for carrying out the method of the present invention which includes the ligase, the plurality of oligonucleotide sets, and the solid support with immobilized capture oligonucleotides.

Another aspect of the present invention relates to a method of forming an array of oligonucleotides on a solid support. This method involves providing a solid support having an array of positions each suitable for attachment of an oligonucleotide. A linker or surface (which can be non-hydrolyzable), suitable for coupling an oligonucleotide to the solid support at each of the array positions, is attached to the solid support. An array of oligonucleotides on a solid support is formed by a series of cycles of activating selected array positions for attachment of multimer nucleotides and attaching multimer nucleotides at the activated array positions.

Yet another aspect of the present invention relates to an array of oligonucleotides on a solid support *per se*. The solid support has an array of positions each suitable for attachment of an oligonucleotide. A linker or support (which can be non-hydrolyzable), suitable for coupling an oligonucleotide to the solid support, is attached to the solid support at each of the array positions. An array of oligonucleotides are placed on a solid support with at least some of the array positions being occupied by oligonucleotides having greater than sixteen nucleotides.

The present invention contains a number of advantages over prior art systems, particularly, its ability to carry out multiplex analyses of complex genetic systems. As a result, a large number of nucleotide sequence differences in a sample can be detected at one time. The present invention is useful for detection of, for example, cancer mutations, inherited (germline) mutations, and infectious diseases. This technology can also be utilized in conjunction with environmental monitoring, forensics, and the food industry.

In addition, the present invention provides quantitative detection of mutations in a high background of normal sequences, allows detection of closely-clustered mutations, permits detection using addressable arrays, and is amenable to automation. By combining the sensitivity of PCR with the specificity of LDR, common difficulties encountered in allele-specific PCR, such as false-positive signal generation, primer interference during multiplexing, limitations in obtaining quantitative data, and suitability for automation, have been obviated. In addition, by relying on the specificity of LDR to distinguish single-base mutations, the major inherent problem of oligonucleotide probe arrays (i.e. their inability to distinguish single-base changes at all positions in heterozygous samples)

has been overcome. PCR/LDR addresses the current needs in cancer detection; to quantify mutations which may serve as clonal markers and to detect minimal residual disease and micrometastases.

5 In carrying out analyses of different samples, the solid support containing the array can be reused. This reduces the quantity of solid supports which need to be manufactured and lowers the cost of analyzing each sample.

The present invention also affords great flexibility in the synthesis of oligonucleotides and their attachment to solid supports. Oligonucleotides can be synthesized off of the solid support and then attached to unique surfaces on the support.  
10 This technique can be used to attach full length oligonucleotides or peptide nucleotide analogues ("PNA") to the solid support. Alternatively, shorter nucleotide or analogue segments (dimer, trimer, tetramer, etc.) can be employed in a segment condensation or block synthesis approach to full length oligomers on the solid support.

## 15 BRIEF DESCRIPTION OF THE DRAWINGS

Figure 1 is a flow diagram depicting polymerase chain reaction ("PCR")/ligase detection reaction ("LDR") processes, according to the prior art and the present invention, for detection of germline mutations, such as point mutations.

20 Figure 2 is a flow diagram depicting PCR/LDR processes, according to the prior art and the present invention, for detection of cancer-associated mutations.

Figure 3 is a schematic diagram depicting a PCR/LDR process, according to the present invention, using addresses on the allele-specific probes for detecting homo- or heterozygosity at two polymorphisms (i.e. allele differences) on the same gene.

25 Figure 4 is a schematic diagram depicting a PCR/LDR process, according to the present invention, using addresses on the allele-specific probes which distinguishes all possible bases at a given site.

Figure 5 is a schematic diagram depicting a PCR/LDR process, according to the present invention, using addresses on the allele-specific probes for detecting the presence  
30 of any possible base at two nearby sites.

Figure 6 is a schematic diagram of a PCR/LDR process, according to the present invention, using addresses on the allele-specific probes distinguishing insertions and deletions.

35 Figure 7 is a schematic diagram of a PCR/LDR process, in accordance with the present invention, using addresses on the allele-specific probes to detect a low abundance mutation (within a codon) in the presence of an excess of normal sequence.

Figure 8 is a schematic diagram of a PCR/LDR process, in accordance with the present invention, where the address is placed on the common probe and the allele differences are distinguished by different fluorescent signals F1, F2, F3, and F4.

Figure 9 is a schematic diagram of a PCR/LDR process, in accordance with the present invention, where both adjacent and nearby alleles are detected.

Figure 10 is a schematic diagram of a PCR/LDR process, in accordance with the present invention, where all possible single-base mutations for a single codon are detected.

5 Figure 11 shows the chemical reactions for covalent modifications, grafting, and oligomer attachment to solid supports.

Figures 12A-C show proposed chemistries for covalent attachment of oligonucleotides to solid supports.

10 Figures 13A-B show two alternative formats for oligonucleotide probe capture. In Figure 13A, the addressable array-specific portions are on the allele-specific probe. Alleles are distinguished by capture of fluorescent signals on addresses Z1 and Z2, respectively. In Figure 13B, the addressable array-specific portions are on the common probe and alleles are distinguished by capture of fluorescent signals F1 and F2, which correspond to the two alleles, respectively.

15 Figures 14A-E depict a protocol for constructing an 8 x 8 array of oligomers by spotting full-length, individual 24 mer oligomers at various sites on a solid support.

Figures 15A-E are perspective views of the 8 x 8 array construction protocol of Figures 14A-E.

20 Figures 16A-C are views of an apparatus used to spot full-length, individual 24 mer oligomers on a solid support in accordance with Figures 14A-E to 15 A-E.

Figure 17 shows a design in accordance with the present invention using 36 tetramers differing by at least 2 bases, which can be used to create a series of unique 24-mers.

25 Figure 18A-G are schematic diagrams showing addition of PNA tetramers to generate a 5 x 5 array of unique 25 mer addresses.

Figures 19A-E depict a protocol for constructing an 8 x 8 array of 24-mers by sequentially coupling 6 tetramers.

Figures 20A-C are perspective views of the 8 x 8 array construction protocol of Figures 19B-C.

30 Figures 21A-G show a schematic cross-sectional view of the synthesis of an addressable array, in accordance with Figures 19B-C.

Figures 22A-C are schematic views of an apparatus used to synthesize the 8 x 8 array of 24 mers on a solid support in accordance with Figures 19B-C, 20A-C, and 21A-G.

35 Figure 19 (Figures 19D-19E).  
Figures 23A-C are perspective views of the 8 x 8 array construction protocol of

Figures 24A-C are schematic views of an apparatus used to synthesize the 5 x 5 array of 24 mers on a solid support, in accordance with Figures 19D-E and 23A-C.

Figures 25A-C are schematic diagrams of a valve block assembly capable of routing six input solutions to 5 output ports.



Figures 26A-D are diagrams of a circular manifold capable of simultaneously channeling 6 input solutions into 5 output ports.

Figure 27 is a schematic drawing of an assay system for carrying out the process of the present invention.

5 Figure 28 shows phosphorimager data for different derivatized surfaces.

Figure 29 shows phosphorimager data for different crosslinking conditions of the polymer matrix.

Figure 30 shows phosphorimager data for -OH functionalized slides.

10 Figure 31 shows the reaction scheme for producing a glass slide silanized with 3-methacryloyloxypropyltrimethoxysilane.

Figure 32 shows the reaction scheme for producing polymerized poly(ethylene glycol)methacrylate on a glass slide silanized with 3-methacryloyloxypropyl-trimethoxysilane.

15 Figure 33 shows the reaction scheme for producing polymerized acrylic acid and trimethylolpropane ethoxylate (14/3 EO/OH) triacrylate on a glass slide silanized with 3-methacryloyloxypropyltrimethoxysilane.

Figure 34 shows the reaction scheme for producing polymerized poly(ethylene glycol)methacrylate and trimethylolpropane ethoxylate (14/3 EO/OH) triacrylate on a glass slide silanized with 3-methacryloyloxypropyltrimethoxysilane.

20

#### DETAILED DESCRIPTION OF THE INVENTION AND DRAWINGS

The present invention relates to a method for identifying one or more of a plurality of sequences differing by one or more single-base changes, insertions, deletions, or  
25 translocations in a plurality of target nucleotide sequences. The method includes a ligation phase, a capture phase, and a detection phase.

The ligation phase requires providing a sample potentially containing one or more nucleotide sequences with a plurality of sequence differences. A plurality of oligonucleotide sets are utilized in this phase. Each set includes a first oligonucleotide  
30 probe, having a target-specific portion and an addressable array-specific portion, and a second oligonucleotide probe, having a target-specific portion and a detectable reporter label. The first and second oligonucleotide probes in a particular set are suitable for ligation together when hybridized adjacent to one another on a corresponding target nucleotide sequence. However, the first and second oligonucleotide probes have a  
35 mismatch which interferes with such ligation when hybridized to another nucleotide sequence present in the sample. A ligase is also utilized. The sample, the plurality of oligonucleotide probe sets, and the ligase are blended to form a mixture. The mixture is subjected to one or more ligase detection reaction cycles comprising a denaturation treatment and a hybridization treatment. The denaturation treatment involves separating  
40 any hybridized oligonucleotides from the target nucleotide sequences. The hybridization

treatment involves hybridizing the oligonucleotide probe sets at adjacent positions in a base-specific manner to their respective target nucleotide sequences, if present in the sample, and ligating them to one another to form a ligated product sequence containing (a) the addressable array-specific portion, (b) the target-specific portions connected together, and (c) the detectable reporter label. The oligonucleotide probe sets may hybridize to nucleotide sequences in the sample other than their respective target nucleotide sequences but do not ligate together due to a presence of one or more mismatches and individually separate during denaturation treatment.

The next phase of the process is the capture phase. This phase involves providing a solid support with capture oligonucleotides immobilized at particular sites. The capture oligonucleotides are complementary to the addressable array-specific portions. The mixture, after being subjected to the ligation phase, is contacted with the solid support under conditions effective to hybridize the addressable array-specific portions to the capture oligonucleotides in a base-specific manner. As a result, the addressable array-specific portions are captured on the solid support at the site with the complementary capture oligonucleotides.

After the capture phase is the detection phase. During this portion of the process, the reporter labels of the ligated product sequences are captured on the solid support at particular sites. When the presence of the reporter label bound to the solid support is detected, the respective presence of one or more nucleotide sequences in the sample is indicated.

Often, a number of different single-base mutations, insertions, or deletions may occur at the same nucleotide position of the sequence of interest. The method provides for having an oligonucleotide set, where the second oligonucleotide probe is common and contains the detectable label, and the first oligonucleotide probe has different addressable array-specific portions and target-specific portions. The first oligonucleotide probe is suitable for ligation to a second adjacent oligonucleotide probe at a first ligation junction, when hybridized without mismatch, to the sequence in question. Different first adjacent oligonucleotide probes would contain different discriminating base(s) at the junction where only a hybridization without mismatch at the junction would allow for ligation. Each first adjacent oligonucleotide would contain a different addressable array-specific portion, and, thus, specific base changes would be distinguished by capture at different addresses. In this scheme, a plurality of different capture oligonucleotides are attached at different locations on the solid support for multiplex detection of additional nucleic acid sequences differing from other nucleic acids by at least a single base. Alternatively, the first oligonucleotide probe contains common addressable array-specific portions, and the second oligonucleotide probes have different detectable labels and target-specific portions.

Such arrangements permit multiplex detection of additional nucleic acid sequences differing from other nucleic acids by at least a single base. The nucleic acids sequences can be on the same or different alleles when carrying out such multiplex detection.

The present invention also relates to a kit for carrying out the method of the present invention which includes the ligase, the plurality of different oligonucleotide probe sets, and the solid support with immobilized capture oligonucleotides. Primers for preliminary amplification of the target nucleotide sequences may also be included in the kit. If  
5 amplification is by polymerase chain reaction, polymerase may also be included in the kit.

Figures 1 and 2 show flow diagrams of the process of the present invention compared to a prior art ligase detection reaction utilizing capillary or gel electrophoresis/fluorescent quantification. Figure 1 relates to detection of a germline mutation detection, while Figure 2 shows the detection of cancer.

10 Figure 1 depicts the detection of a germline point mutation, such as the p53 mutations responsible for Li-Fraumeni syndrome. In step 1, after DNA sample preparation, exons 5-8 are PCR amplified using *Taq* (i.e. *Thermus aquaticus*) polymerase under hot start conditions. At the end of the reaction, *Taq* polymerase is degraded by heating at 100°C for 10 min. Products are diluted 20-fold in step 2 into fresh LDR buffer  
15 containing allele-specific and common LDR probes. A tube generally contains about 100 to 200 fmoles of each primer. In step 3, the ligase detection reaction is initiated by addition of *Taq* ligase under hot start conditions. The LDR probes ligate to their adjacent probes only in the presence of target sequence which gives perfect complementarity at the junction site. The products may be detected in two different formats. In the first format  
20 4a., used in the prior art, fluorescently-labeled LDR probes contain different length poly A or hexaethylene oxide tails. Thus, each LDR product, resulting from ligation to normal DNA with a slightly different mobility, yields a ladder of peaks. A germline mutation would generate a new peak on the electrophorogram. The size of the new peak will approximate the amount of the mutation present in the original sample; 0% for  
25 homozygous normal, 50% for heterozygous carrier, or 100% for homozygous mutant. In the second format 4b., in accordance with the present invention, each allele-specific probe contains e.g., 24 additional nucleotide bases on their 5' ends. These sequences are unique addressable sequences which will specifically hybridize to their complementary address sequences on an addressable array. In the LDR reaction, each allele-specific probe can  
30 ligate to its adjacent fluorescently labeled common probe in the presence of the corresponding target sequence. Wild type and mutant alleles are captured on adjacent addresses on the array. Unreacted probes are washed away. The black dots indicate 100% signal for the wild type allele. The white dots indicate 0% signal for the mutant alleles. The shaded dots indicate the one position of germline mutation, 50% signal for each allele.

35 Figure 2 depicts detection of somatic cell mutations in the p53 tumor suppressor gene but is general for all low sensitivity mutation detection. In step 1, DNA samples are prepared and exons 5-9 are PCR amplified as three fragments using fluorescent PCR primers. This allows for fluorescent quantification of PCR products in step 2 using capillary or gel electrophoresis. In step 3, the products are spiked with a 1/100 dilution of  
40 marker DNA (for each of the three fragments). This DNA is homologous to wild type

DNA, except it contains a mutation which is not observed in cancer cells, but which may be readily detected with the appropriate LDR probes. The mixed DNA products in step 4 are diluted 20-fold into buffer containing all the LDR probes which are specific only to mutant or marker alleles. In step 5, the ligase reaction is initiated by addition of *Taq* ligase under hot start conditions. The LDR probes ligate to their adjacent probes only in the presence of target sequences which give perfect complementarity at the junction site. The products may be detected in the same two formats described in Figure 1. In the format of step 6a, which is used in the prior art, products are separated by capillary or gel electrophoresis, and fluorescent signals are quantified. Ratios of mutant peaks to marker peaks give approximate amount of cancer mutations present in the original sample divided by 100. In the format of step 6b, in accordance with the present invention, products are detected by specific hybridization to complementary sequences on an addressable array. Ratios of fluorescent signals in mutant dots to marker dots give the approximate amount of cancer mutations present in the original sample divided by 100.

The ligase detection reaction process, in accordance with the present invention, is best understood by referring to Figures 3-10. It is described generally in WO 90/17239 to Barany et al., F. Barany et al., "Cloning, Overexpression and Nucleotide Sequence of a Thermostable DNA Ligase-encoding Gene," *Gene*, 109:1-11 (1991), and F. Barany, "Genetic Disease Detection and DNA Amplification Using Cloned Thermostable Ligase." *Proc. Natl. Acad. Sci. USA*, 88:189-193 (1991), the disclosures of which are hereby incorporated by reference. In accordance with the present invention, the ligase detection reaction can use 2 sets of complementary oligonucleotides. This is known as the ligase chain reaction which is described in the 3 immediately preceding references, which are hereby incorporated by reference. Alternatively, the ligase detection reaction can involve a single cycle which is known as the oligonucleotide ligation assay. See Landegren, et al., "A Ligase-Mediated Gene Detection Technique," *Science* 241:1077-80 (1988); Landegren, et al., "DNA Diagnostics -- Molecular Techniques and Automation," *Science* 242:229-37 (1988); and U.S. Patent No. 4,988,617 to Landegren, et al.

During the ligase detection reaction phase of the process, the denaturation treatment is carried out at a temperature of 80-105°C, while hybridization takes place at 50-85°C. Each cycle comprises a denaturation treatment and a thermal hybridization treatment which in total is from about one to five minutes long. Typically, the ligation detection reaction involves repeatedly denaturing and hybridizing for 2 to 50 cycles. The total time for the ligase detection reaction phase of the process is 1 to 250 minutes.

The oligonucleotide probe sets can be in the form of ribonucleotides, deoxynucleotides, modified ribonucleotides, modified deoxyribonucleotides, peptide nucleotide analogues, modified peptide nucleotide analogues, modified phosphate-sugar-backbone oligonucleotides, nucleotide analogs, and mixtures thereof.

In one variation, the oligonucleotides of the oligonucleotide probe sets each have a hybridization or melting temperature (i.e.  $T_m$ ) of 66-70°C. These oligonucleotides are 20-28 nucleotides long.

It may be desirable to destroy chemically or enzymatically unconverted LDR  
5 oligonucleotide probes that contain addressable nucleotide array-specific portions prior to capture of the ligation products on a DNA array. Such unconverted probes will otherwise compete with ligation products for binding at the addresses on the array of the solid support which contain complementary sequences. Destruction can be accomplished by utilizing an exonuclease, such as exonuclease III (L-H Guo and R. Wu, Methods in  
10 Enzymology 100:60-96 (1985), which is hereby incorporated by reference) in combination with LDR probes that are blocked at the ends and not involved with ligation of probes to one another. The blocking moiety could be a reporter group or a phosphorothioate group. T.T. Nikiforow, et al., "The Use of Phosphorothioate Primers and Exonuclease Hydrolysis for the Preparation of Single-stranded PCR Products and their Detection by Solid-phase  
15 Hybridization," PCR Methods and Applications, 3:p.285-291 (1994), which is hereby incorporated by reference. After the LDR process, unligated probes are selectively destroyed by incubation of the reaction mixture with the exonuclease. The ligated probes are protected due to the elimination of free 3' ends which are required for initiation of the exonuclease reaction. This approach results in an increase in the signal-to-noise ratio,  
20 especially where the LDR reaction forms only a small amount of product. Since unligated oligonucleotides compete for capture by the capture oligonucleotide, such competition with the ligated oligonucleotides lowers the signal. An additional advantage of this approach is that unhybridized label-containing sequences are degraded and, therefore, are less able to cause a target-independent background signal, because they can be removed  
25 more easily from the DNA array by washing.

The oligonucleotide probe sets, as noted above, have a reporter label suitable for detection. Useful labels include chromophores, fluorescent moieties, enzymes, antigens, heavy metals, magnetic probes, dyes, phosphorescent groups, radioactive materials, chemiluminescent moieties, and electrochemical detecting moieties. The capture  
30 oligonucleotides can be in the form of ribonucleotides, deoxyribonucleotides, modified ribonucleotides, modified deoxyribonucleotides, peptide nucleotide analogues, modified peptide nucleotide analogues, modified phosphate-sugar backbone oligonucleotides, nucleotide analogues, and mixtures thereof. Where the process of the present invention involves use of a plurality of oligonucleotide sets, the second oligonucleotide probes can  
35 be the same, while the addressable array-specific portions of the first oligonucleotide probes differ. Alternatively, the addressable array-specific portions of the first oligonucleotide probes may be the same, while the reporter labels of the second oligonucleotide probes are different.

Prior to the ligation detection reaction phase of the present invention, the sample is  
40 preferably amplified by an initial target nucleic acid amplification procedure. This

increases the quantity of the target nucleotide sequence in the sample. For example, the initial target nucleic acid amplification may be accomplished using the polymerase chain reaction process, self-sustained sequence replication, or Q- $\beta$  replicase-mediated RNA amplification. The polymerase chain reaction process is the preferred amplification

5 procedure and is fully described in H. Erlich, et. al., "Recent Advances in the Polymerase Chain Reaction," Science 252: 1643-50 (1991); M. Innis, et. al., PCR Protocols: A Guide to Methods and Applications, Academic Press: New York (1990); and R. Saiki, et. al., "Primer-directed Enzymatic Amplification of DNA with a Thermostable DNA

10 Polymerase," Science 239: 487-91 (1988), which are hereby incorporated by reference. J. Guatelli, et. al., "Isothermal, *in vitro* Amplification of Nucleic Acids by a Multienzyme Reaction Modeled After Retroviral Replication," Proc. Natl. Acad. Sci. USA 87: 1874-78 (1990), which is hereby incorporated by reference, describes the self-sustained sequence replication process. The Q- $\beta$  replicase-mediated RNA amplification is disclosed in F. Kramer, et. al., "Replicable RNA Reporters," Nature 339: 401-02 (1989), which is

15 hereby incorporated by reference.

The use of the polymerase chain reaction process and then the ligase detection process, in accordance with the present invention, is shown in Figure 3. Here, homo- or heterozygosity at two polymorphisms (i.e. allele differences) are on the same gene. Such allele differences can alternatively be on different genes.

20 As shown in Figure 3, the target nucleic acid, when present in the form of a double stranded DNA molecule is denatured to separate the strands. This is achieved by heating to a temperature of 80-105°C. Polymerase chain reaction primers are then added and allowed to hybridize to the strands, typically at a temperature of 20-85°C. A thermostable polymerase (e.g., *Thermus aquaticus* polymerase) is also added, and the temperature is

25 then adjusted to 50-85°C to extend the primer along the length of the nucleic acid to which the primer is hybridized. After the extension phase of the polymerase chain reaction, the resulting double stranded molecule is heated to a temperature of 80-105°C to denature the molecule and to separate the strands. These hybridization, extension, and denaturation steps may be repeated a number of times to amplify the target to an appropriate level.

30 Once the polymerase chain reaction phase of the process is completed, the ligation detection reaction phase begins, as shown in Figure 3. After denaturation of the target nucleic acid, if present as a double stranded DNA molecule, at a temperature of 80-105°C, preferably 94°C, ligation detection reaction oligonucleotide probes for one strand of the target nucleotide sequence are added along with a ligase (for example, as shown in Figure

35 3, a thermostable ligase like *Thermus aquaticus* ligase). The oligonucleotide probes are then allowed to hybridize to the target nucleic acid molecule and ligate together, typically, at a temperature of 45-85°C, preferably, 65°C. When there is perfect complementarity at the ligation junction, the oligonucleotides can be ligated together. Where the variable nucleotide is T or A, the presence of T in the target nucleotide sequence will cause the

40 oligonucleotide probe with the addressable array-specific portion Z1 to ligate to the

oligonucleotide probe with the reporter label F, and the presence of A in the target nucleotide sequence will cause the oligonucleotide probe with the addressable array-specific portion Z2 to ligate to the oligonucleotide probe with reporter label F. Similarly, where the variable nucleotide is A or G, the presence of T in the target nucleotide sequence will cause the oligonucleotide probe with addressable array-specific portion Z4 to ligate to the oligonucleotide probe with the reporter label F, and the presence of C in the target nucleotide sequence will cause the oligonucleotide probe with the addressable array-specific portion Z3 to ligate to the oligonucleotide probe with reporter label F. Following ligation, the material is again subjected to denaturation to separate the hybridized strands.

10 The hybridization/ligation and denaturation steps can be carried through one or more cycles (e.g., 1 to 50 cycles) to amplify the target signal. Fluorescent ligation products (as well as unligated oligonucleotide probes having an addressable array-specific portion) are captured by hybridization to capture probes complementary to portions Z1, Z2, Z3, and Z4 at particular addresses on the addressable arrays. The presence of ligated oligonucleotides is then detected by virtue of the label F originally on one of the oligonucleotides.

15 Figure 3, ligated product sequences hybridize to the array at addresses with capture oligonucleotides complementary to addressable array-specific portions Z1 and Z3, while unligated oligonucleotide probes with addressable array-specific portions Z2 and Z4 hybridize to their complementary capture oligonucleotides. However, since only the

20 ligated product sequences have label F, only their presence is detected.

Figure 4 is a flow diagram of a PCR/LDR process, in accordance with the present invention, which distinguishes any possible base at a given site. Appearance of fluorescent signal at the addresses complementary to addressable array-specific portions Z1, Z2, Z3, and Z4 indicates the presence of A, G, C, and T alleles in the target nucleotide sequence, respectively. Here, the presence of the A and C alleles in the target nucleotide sequences is indicated due to the fluorescence at the addresses on the solid support with capture oligonucleotide probes complementary to portions Z1 and Z3, respectively. Note that in Figure 4 the addressable array-specific portions are on the discriminating oligonucleotide probes, and the discriminating base is on the 3' end of these probes.

30 Figure 5 is a flow diagram of a PCR/LDR process, in accordance with the present invention, for detecting the presence of any possible base at two nearby sites. Here, the LDR primers are able to overlap, yet are still capable of ligating provided there is perfect complementarity at the junction. This distinguishes LDR from other approaches, such as allele-specific PCR where overlapping primers would interfere with one another. In

35 Figure 5, the first nucleotide position is heterozygous at the A and C alleles, while the second nucleotide position is heterozygous to the G, C, and T alleles. As in Figure 4, the addressable array-specific portions are on the discriminating oligonucleotide probes, and the discriminating base is on the 3' end of these probes. The reporter group (e.g., the fluorescent label) is on the 3' end of the common oligonucleotide probes. This is possible

40 for example with the 21 hydroxylase gene, where each individual has 2 normal and 2

pseudogenes, and, at the intron 2 splice site (nucleotide 656), there are 3 possible single bases (G, A, and C). Also, this can be used to detect low abundance mutations in HIV infections which might indicate emergence of drug resistant (e.g., to AZT) strains.

Returning to Figure 5, appearance of fluorescent signal at the addresses complementary to addressable array-specific portions Z1, Z2, Z3, Z4, Z5, Z6, Z7, and Z8 indicates the presence of the A, G, C, and T, respectively, in the site heterozygous at the A and C alleles, and A, G, C, and T, respectively, in the site heterozygous at the G, C, and T alleles.

Figure 6 is a flow diagram of a PCR/LDR process, in accordance with the present invention, where insertions (top left set of probes) and deletions (bottom right set of probes) are distinguished. On the left, the normal sequence contains 5 A's in a polyA tract. The mutant sequence has an additional 2As inserted into the tract. Therefore, the LDR products with addressable array-specific portions Z1 (representing the normal sequence) and Z3 (representing a 2 base pair insertion) would be fluorescently labeled by ligation to the common primer. While the LDR process (e.g., using a thermostable ligase enzyme) has no difficulty distinguishing single base insertions or deletions in mononucleotide repeats, allele-specific PCR is unable to distinguish such differences, because the 3' base remains the same for both alleles. On the right, the normal sequence is a (CA)<sub>5</sub> repeat (i.e. CACACACACA). The mutant contains two less CA bases than the normal sequence (i.e. CACACA). These would be detected as fluorescent LDR products at the addressable array-specific portions Z8 (representing the normal sequence) and Z6 (representing the 2 CA deletion) addresses. The resistance of various infectious agents to drugs can also be determined using the present invention. In Figure 6, the presence of ligated product sequences, as indicated by fluorescent label F, at the address having capture oligonucleotides complementary to Z1 and Z3 demonstrates the presence of both the normal and mutant poly A sequences. Similarly, the presence of ligated product sequences, as indicated by fluorescent label F, at the address having capture oligonucleotides complementary to Z6 and Z8 demonstrates the presence of both the normal CA repeat and a sequence with one repeat unit deleted.

Figure 7 is a flow diagram of a PCR/LDR process, in accordance with the present invention, using addressable array-specific portions to detect a low abundance mutation in the presence of an excess of normal sequence. Figure 7 shows codon 12 of the K-ras gene. sequence GGT, which codes for glycine ("Gly"). A small percentage of the cells contain the G to A mutation in GAT, which codes for aspartic acid ("Asp"). The LDR probes for wild-type (i.e. normal sequences) are missing from the reaction. If the normal LDR probes (with the discriminating base = G) were included, they would ligate to the common probes and overwhelm any signal coming from the mutant target. Instead, as shown in Figure 7, the existence of a ligated product sequence with fluorescent label F at the address with a capture oligonucleotide complementary to addressable array-specific portion Z4 indicates the presence of the aspartic acid encoding mutant.



Figure 8 is a flow diagram of a PCR/LDR process, in accordance with the present invention, where the addressable array-specific portion is placed on the common oligonucleotide probe, while the discriminating oligonucleotide probe has the reporter label. Allele differences are distinguished by different fluorescent signals, F1, F2, F3, and F4. This mode allows for a more dense use of the arrays, because each position is predicted to light up with some group. It has the disadvantage of requiring fluorescent groups which have minimal overlap in their emission spectra and will require multiple scans. It is not ideally suitable for detection of low abundance alleles (e.g., cancer associated mutations).

Figure 9 is a flow diagram of a PCR/LDR process, in accordance with the present invention, where both adjacent and nearby alleles are detected. The adjacent mutations are right next to each other, and one set of oligonucleotide probes discriminates the bases on the 3' end of the junction (by use of different addressable array-specific portions Z1, Z2, Z3, and Z4), while the other set of oligonucleotide probes discriminates the bases on the 5' end of the junction (by use of different fluorescent reporter labels F1, F2, F3, and F4). In Figure 9, codons in a disease gene (e.g. CFTR for cystic fibrosis) encoding Gly and arginine ("Arg"), respectively, are candidates for germline mutations. The detection results in Figure 9 show the Gly (GGA; indicated by the ligated product sequence having portion Z2 and label F2) has been mutated to glutamic acid ("Glu") (GAA; indicated by the ligated product sequence having portion Z2 and label F1), and the Arg (CGG; indicated by the ligated product sequence having portion Z7 and label F2) has been mutated to tryptophan ("Trp") (TGG; indicated by the ligated product sequence with portion Z8 and label F2). Therefore, the patient is a compound heterozygous individual (i.e. with allele mutations in both genes) and will have the disease.

Figure 10 is a flow diagram of a PCR/LDR process, in accordance with the present invention, where all possible single-base mutations for a single codon are detected. Most amino acid codons have a degeneracy in the third base, thus the first two positions can determine all the possible mutations at the protein level. These amino acids include arginine, leucine, serine, threonine, proline, alanine, glycine, and valine. However, some amino acids are determined by all three bases in the codon and, thus, require the oligonucleotide probes to distinguish mutations in 3 adjacent positions. By designing four oligonucleotide probes containing the four possible bases in the penultimate position to the 3' end, as well as designing an additional four capture oligonucleotides containing the four possible bases at the 3' end, as shown in Figure 10, this problem has been solved. The common oligonucleotide probes with the reporter labels only have two fluorescent groups which correspond to the codon degeneracies and distinguish between different ligated product sequences which are captured at the same array address. For example, as shown in Figure 10, the presence of a glutamine ("Gln") encoding codon (i.e., CAA and CAG) is indicated by the presence of a ligated product sequence containing portion Z1 and label F2. Likewise, the existence of a Gln to histidine ("His") encoding mutation (coded

by the codon CAC) is indicated by the presence of ligated product sequences with portion Z1 and label F2 and with portion Z7 and label F2. There is an internal redundancy built into this assay due to the fact that primers Z1 and Z7 have the identical sequence.

5 A particularly important aspect of the present invention is its capability to quantify the amount of target nucleotide sequence in a sample. This can be achieved in a number of ways by establishing standards which can be internal (i.e. where the standard establishing material is amplified and detected with the sample) or external (i.e. where the standard establishing material is not amplified, and is detected with the sample).

10 In accordance with one quantification method, the signal generated by the reporter label, resulting from capture of ligated product sequences produced from the sample being analyzed, are detected. The strength of this signal is compared to a calibration curve produced from signals generated by capture of ligated product sequences in samples with known amounts of target nucleotide sequence. As a result, the amount of target nucleotide sequence in the sample being analyzed can be determined. This techniques involves use  
15 of an external standard.

Another quantification method, in accordance with the present invention, relates to an internal standard. Here, a known amount of one or more marker target nucleotide sequences are added to the sample. In addition, a plurality of marker-specific oligonucleotide probe sets are added along with the ligase, the previously-discussed  
20 oligonucleotide probe sets, and the sample to a mixture. The marker-specific oligonucleotide probe sets have (1) a first oligonucleotide probe with a target-specific portion complementary to the marker target nucleotide sequence and an addressable array-specific portion complementary to capture oligonucleotides on the solid support and (2) a  
25 target nucleotide sequence and a detectable reporter label. The oligonucleotide probes in a particular marker-specific oligonucleotide set are suitable for ligation together when hybridized adjacent to one another on a corresponding marker target nucleotide sequence. However, there is a mismatch which interferes with such ligation when hybridized to any  
30 other nucleotide sequence present in the sample or added marker sequences. The presence of ligated product sequences captured on the solid support is identified by detection of reporter labels. The amount of target nucleotide sequences in the sample is then determined by comparing the amount of captured ligated product generated from known amounts of marker target nucleotide sequences with the amount of other ligated product sequences captured.

35 Another quantification method in accordance with the present invention involves analysis of a sample containing two or more of a plurality of target nucleotide sequences with a plurality of sequence differences. Here, ligated product sequences corresponding to the target nucleotide sequences are detected and distinguished by any of the previously-discussed techniques. The relative amounts of the target nucleotide sequences in the  
40 sample are then quantified by comparing the relative amounts of captured ligated product

sequences generated. This provides a quantitative measure of the relative level of the target nucleotide sequences in the sample.

The ligase detection reaction process phase of the present invention can be preceded by the ligase chain reaction process to achieve oligonucleotide product  
5 amplification. This process is fully described in F. Barany, et. al., "Cloning, Overexpression and Nucleotide Sequence of a Thermostable DNA Ligase-encoding Gene," Gene 109: 1-11 (1991) and F. Barany, "Genetic Disease Detection and DNA Amplification Using Cloned Thermostable Ligase," Proc. Natl. Acad. Sci. USA 88: 189-93 (1991), which are hereby incorporated by reference. Instead of using the ligase chain  
10 reaction to achieve amplification, a transcription-based amplifying procedure can be used.

The preferred thermostable ligase is that derived from *Thermus aquaticus*. This enzyme can be isolated from that organism. M. Takahashi, et al., "Thermophilic DNA Ligase," J. Biol. Chem. 259:10041-47 (1984), which is hereby incorporated by reference. Alternatively, it can be prepared recombinantly. Procedures for such isolation as well as  
15 the recombinant production of *Thermus aquaticus* ligase as well as *Thermus thermophilus* ligase) are disclosed in WO 90/17239 to Barany, et. al., and F. Barany, et al., "Cloning, Overexpression and Nucleotide Sequence of a Thermostable DNA-Ligase Encoding Gene," Gene 109:1-11 (1991), which are hereby incorporated by reference. These references contain complete sequence information for this ligase as well as the encoding  
20 DNA. Other suitable ligases include *E. coli* ligase, T4 ligase, and *Pyrococcus* ligase.

The ligation amplification mixture may include a carrier DNA, such as salmon sperm DNA.

The hybridization step, which is preferably a thermal hybridization treatment, discriminates between nucleotide sequences based on a distinguishing nucleotide at the  
25 ligation junctions. The difference between the target nucleotide sequences can be, for example, a single nucleic acid base difference, a nucleic acid deletion, a nucleic acid insertion, or rearrangement. Such sequence differences involving more than one base can also be detected. Preferably, the oligonucleotide probe sets have substantially the same  
30 length so that they hybridize to target nucleotide sequences at substantially similar hybridization conditions. As a result, the process of the present invention is able to detect infectious diseases, genetic diseases, and cancer. It is also useful in environmental monitoring, forensics, and food science.

A wide variety of infectious diseases can be detected by the process of the present invention. Typically, these are caused by bacterial, viral, parasite, and fungal infectious  
35 agents. The resistance of various infectious agents to drugs can also be determined using the present invention.

Bacterial infectious agents which can be detected by the present invention include  
40 *Escherichia coli*, *Salmonella*, *Shigella*, *Klebsiella*, *Pseudomonas*, *Listeria monocytogenes*, *Mycobacterium tuberculosis*, *Mycobacterium avium-intracellulare*, *Yersinia*, *Francisella*, *Pasteurella*, *Brucella*, *Clostridia*, *Bordetella pertussis*, *Bacteroides*, *Staphylococcus*

*aureus*, *Streptococcus pneumonia*, B-Hemolytic strep., *Corynebacteria*, *Legionella*, *Mycoplasma*, *Ureaplasma*, *Chlamydia*, *Neisseria gonorrhoea*, *Neisseria meningitidis*, *Hemophilus influenza*, *Enterococcus faecalis*, *Proteus vulgaris*, *Proteus mirabilis*, *Helicobacter pylori*, *Treponema palladium*, *Borrelia burgdorferi*, *Borrelia recurrentis*,  
5 *Rickettsial* pathogens, *Nocardia*, and *Acitnomycetes*.

Fungal infectious agents which can be detected by the present invention include *Cryptococcus neoformans*, *Blastomyces dermatitidis*, *Histoplasma capsulatum*, *Coccidioides immitis*, *Paracoccidioides brasiliensis*, *Candida albicans*, *Aspergillus fumigatus*, *Phycomycetes (Rhizopus)*, *Sporothrix schenckii*, *Chromomycosis*, and  
10 *Maduromycosis*.

Viral infectious agents which can be detected by the present invention include human immunodeficiency virus, human T-cell lymphocytotropic virus, hepatitis viruses (e.g., Hepatitis B Virus and Hepatitis C Virus), Epstein-Barr Virus, cytomegalovirus, human papillomaviruses, orthomyxo viruses, paramyxo viruses, adenoviruses, corona  
15 viruses, rhabdo viruses, polio viruses, toga viruses, bunya viruses, arena viruses, rubella viruses, and reo viruses.

Parasitic agents which can be detected by the present invention include *Plasmodium falciparum*, *Plasmodium malaria*, *Plasmodium vivax*, *Plasmodium ovale*, *Onchoverva volvulus*, *Leishmania*, *Trypanosoma* spp., *Schistosoma* spp., *Entamoeba*  
20 *histolytica*, *Cryptosporidium*, *Giardia* spp., *Trichimonas* spp., *Balatidium coli*, *Wuchereria bancrofti*, *Toxoplasma* spp., *Enterobius vermicularis*, *Ascaris lumbricoides*, *Trichuris trichiura*, *Dracunculus medinesis*, trematodes, *Diphyllobothrium latum*, *Taenia* spp., *Pneumocystis carinii*, and *Necator americanis*.

The present invention is also useful for detection of drug resistance by infectious  
25 agents. For example, vancomycin-resistant *Enterococcus faecium*, methicillin-resistant *Staphylococcus aureus*, penicillin-resistant *Streptococcus pneumoniae*, multi-drug resistant *Mycobacterium tuberculosis*, and AZT-resistant human immunodeficiency virus can all be identified with the present invention.

Genetic diseases can also be detected by the process of the present invention. This  
30 can be carried out by prenatal screening for chromosomal and genetic aberrations or post natal screening for genetic diseases. Examples of detectable genetic diseases include: 21 hydroxylase deficiency, cystic fibrosis, Fragile X Syndrome, Turner Syndrome, Duchenne Muscular Dystrophy, Down Syndrome or other trisomies, heart disease, single gene diseases, HLA typing, phenylketonuria, sickle cell anemia, Tay-Sachs Syndrome,  
35 thalassemia, Klinefelter's Syndrome, Huntington's Disease, autoimmune diseases, lipidosis, obesity defects, hemophilia, inborn errors in metabolism, and diabetes.

Cancers which can be detected by the process of the present invention generally involve oncogenes, tumor suppressor genes, or genes involved in DNA amplification, replication, recombination, or repair. Examples of these include: BRCA1 gene, p53 gene,  
40 *Familial polyposis coli*, Her2/Neu amplification, Bcr/Ab1, K-ras gene, human

papillomavirus Types 16 and 18, leukemia, colon cancer, breast cancer, lung cancer, prostate cancer, brain tumors, central nervous system tumors, bladder tumors, melanomas, liver cancer, osteosarcoma and other bone cancers, testicular and ovarian carcinomas, ENT tumors, and loss of heterozygosity.

5 In the area of environmental monitoring, the present invention can be used for detection, identification, and monitoring of pathogenic and indigenous microorganisms in natural and engineered ecosystems and microcosms such as in municipal waste water purification systems and water reservoirs or in polluted areas undergoing  
10 bioremediation. It is also possible to detect plasmids containing genes that can metabolize xenobiotics, to monitor specific target microorganisms in population dynamic studies, or either to detect, identify, or monitor genetically modified microorganisms in the environment and in industrial plants.

The present invention can also be used in a variety of forensic areas, including for human identification for military personnel and criminal investigation, paternity  
15 testing and family relation analysis, HLA compatibility typing, and screening blood, sperm, or transplantation organs for contamination.

In the food and feed industry, the present invention has a wide variety of applications. For example, it can be used for identification and characterization of production organisms such as yeast for production of beer, wine, cheese, yogurt, bread,  
20 etc. Another area of use is with regard to quality control and certification of products and processes (e.g., livestock, pasteurization, and meat processing) for contaminants. Other uses include the characterization of plants, bulbs, and seeds for breeding purposes, identification of the presence of plant-specific pathogens, and detection and identification of veterinary infections.

25 Desirably, the oligonucleotide probes are suitable for ligation together at a ligation junction when hybridized adjacent to one another on a corresponding target nucleotide sequence due to perfect complementarity at the ligation junction. However, when the oligonucleotide probes in the set are hybridized to any other nucleotide sequence present  
30 in the sample, there is a mismatch at a base at the ligation junction which interferes with ligation. Most preferably, the mismatch is at the base adjacent the 3' base at the ligation junction. Alternatively, the mismatch can be at the bases adjacent to bases at the ligation junction.

The process of the present invention is able to detect the first and second nucleotide sequences in the sample in an amount of 100 attomoles to 250 femtomoles. By  
35 coupling the LDR step with a primary polymerase-directed amplification step, the entire process of the present invention is able to detect target nucleotide sequences in a sample containing as few as a single molecule. Furthermore, PCR amplified products, which often are in the picomole amounts, may easily be diluted within the above range. The ligase detection reaction achieves a rate of formation of mismatched ligated product

sequences which is less than .005 of the rate of formation of matched ligated product sequences.

Once the ligation phase of the process is completed, the capture phase is initiated. During the capture phase of the process, the mixture is contacted with the solid support at  
5 a temperature of 45-90°C and for a time period of up to 60 minutes. Hybridizations may be accelerated by adding volume exclusion or chaotropic agents. When an array consists of dozens to hundreds of addresses, it is important that the correct ligation products have an opportunity to hybridize to the appropriate address. This may be achieved by the thermal motion of oligonucleotides at the high temperatures used, by mechanical  
10 movement of the fluid in contact with the array surface, or by moving the oligonucleotides across the array by electric fields. After hybridization, the array is washed sequentially with a low stringency wash buffer and then a high stringency wash buffer.

It is important to select capture oligonucleotides and addressable nucleotide sequences which will hybridize in a stable fashion. This requires that the oligonucleotide  
15 sets and the capture oligonucleotides be configured so that the oligonucleotide sets hybridize to the target nucleotide sequences at a temperature less than that which the capture oligonucleotides hybridize to the addressable array-specific portions. Unless the oligonucleotides are designed in this fashion, false positive signals may result due to capture of adjacent unreacted oligonucleotides from the same oligonucleotide set which  
20 are hybridized to the target.

The detection phase of the process involves scanning and identifying if ligation of particular oligonucleotide sets occurred and correlating ligation to a presence or absence of the target nucleotide sequence in the test sample. Scanning can be carried out by scanning  
25 electron microscopy, confocal microscopy, charge-coupled device, scanning tunneling electron microscopy, infrared microscopy, atomic force microscopy, electrical conductance, and fluorescent or phosphor imaging. Correlating is carried out with a computer.

Another aspect of the present invention relates to a method of forming an array of oligonucleotides on a solid support. This method involves providing a solid support  
30 having an array of positions each suitable for attachment of an oligonucleotide. A linker or support (preferably non-hydrolyzable), suitable for coupling an oligonucleotide to the solid support at each of the array positions, is attached to the solid support. An array of oligonucleotides on a solid support is formed by a series of cycles of activating selected array positions for attachment of multimer nucleotides and attaching multimer nucleotides  
35 at the activated array positions.

Yet another aspect of the present invention relates to an array of oligonucleotides on a solid support *per se*. The solid support has an array of positions each suitable for an attachment of an oligonucleotide. A linker or support (preferably non-hydrolyzable),  
40 suitable for coupling an oligonucleotide to the solid support, is attached to the solid support at each of the array positions. An array of oligonucleotides are placed on a solid

support with at least some of the array positions being occupied by oligonucleotides having greater than sixteen nucleotides.

In the method of forming arrays, multimer oligonucleotides from different multimer oligonucleotide sets are attached at different array positions on a solid support.

5 As a result, the solid support has an array of positions with different groups of multimer oligonucleotides attached at different positions.

The 1,000 different addresses can be unique capture oligonucleotide sequences (e.g., 24-mer) linked covalently to the target-specific sequence (e.g., approximately 20- to 25-mer) of a LDR oligonucleotide probe. A capture oligonucleotide probe sequence does  
10 not have any homology to either the target sequence or to other sequences on genomes which may be present in the sample. This oligonucleotide probe is then captured by its addressable array-specific portion, a sequence complementary to the capture oligonucleotide on the addressable solid support array. The concept is shown in two possible formats, for example, for detection of the p53 R248 mutation (Figures 13A-B).

15 In Figures 13A-B, the top portion of the diagram shows two alternative formats for oligonucleotide probe design to identify the presence of a germ line mutation in codon 248 of the p53 tumor suppressor gene. The wild type sequence codes for arginine (R248), while the cancer mutation codes for tryptophan (R248W). The bottom part of the diagram is a schematic diagram of the capture oligonucleotide. The thick horizontal line depicts  
20 the membrane or solid surface containing the addressable array. The thin curved lines indicate a flexible linker arm. The thicker lines indicate a capture oligonucleotide sequence, attached to the solid surface in the C to N direction. For illustrative purposes, the capture oligonucleotides are drawn vertically, making the linker arm in section B appear "stretched". Since the arm is flexible, the capture oligonucleotide will be able to  
25 hybridize 5' to C and 3' to N in each case, as dictated by base pair complementarity. A similar orientation of oligonucleotide hybridization would be allowed if the oligonucleotides were attached to the membrane at the N-terminus. In this case, DNA/PNA hybridization would be in standard antiparallel 5' to 3' and 3' to 5'. Other modified sugar-phosphate backbones would be used in a similar fashion. Figure 13A  
30 shows two LDR primers that are designed to discriminate wild type and mutant p53 by containing the discriminating base C or T at the 3' end. In the presence of the correct target DNA and *Tth* ligase, the discriminating probe is covalently attached to a common downstream oligonucleotide. The downstream oligonucleotide is fluorescently labeled. The discriminating oligonucleotides are distinguished by the presence of unique  
35 addressable array-specific portions, Z1 and Z2, at each of their 5' ends. A black dot indicates that target dependent ligation has taken place. After ligation, oligonucleotide probes may be captured by their complementary addressable array-specific portions at unique addresses on the array. Both ligated and unreacted oligonucleotide probes are captured by the oligonucleotide array. Unreacted fluorescently labeled common primers  
40 and target DNA are then washed away at a high temperature (approximately 65°C to

80°C) and low salt. Mutant signal is distinguished by detection of fluorescent signal at the capture oligonucleotide complementary to addressable array-specific portion Z1, while wild type signal appears at the capture oligonucleotide complementary to addressable array-specific portion Z2. Heterozygosity is indicated by equal signals at the capture  
5 oligonucleotides complementary to addressable array-specific portions Z1 and Z2. The signals may be quantified using a fluorescent imager. This format uses a unique address for each allele and may be preferred for achieving very accurate detection of low levels of signal (30 to 100 attomoles of LDR product). Figure 13B shows the discriminating signals may be quantified using a fluorescent imager. This format uses a unique address  
10 where oligonucleotide probes are distinguished by having different fluorescent groups, F1 and F2, on their 5' end. Either oligonucleotide probe may be ligated to a common downstream oligonucleotide probe containing an addressable array-specific portion Z1 on its 3' end. In this format, both wild type and mutant LDR products are captured at the same address on the array, and are distinguished by their different fluorescence. This  
15 format allows for a more efficient use of the array and may be preferred when trying to detect hundreds of potential germline mutations.

The solid support can be made from a wide variety of materials. The substrate may be biological, nonbiological, organic, inorganic, or a combination of any of these, existing as particles, strands, precipitates, gels, sheets, tubing, spheres, containers,  
20 capillaries, pads, slices, films, plates, slides, discs, membranes, etc. The substrate may have any convenient shape, such as a disc, square, circle, etc. The substrate is preferably flat but may take on a variety of alternative surface configurations. For example, the substrate may contain raised or depressed regions on which the synthesis takes place. The substrate and its surface preferably form a rigid support on which to carry out the reactions  
25 described herein. The substrate and its surface is also chosen to provide appropriate light-absorbing characteristics. For instance, the substrate may be a polymerized Langmuir Blodgett film, functionalized glass, Si, Ge, GaAs, GaP, SiO<sub>2</sub>, SiN<sub>4</sub>, modified silicon, or any one of a wide variety of gels or polymers such as (poly)tetrafluoroethylene, (poly)vinylidenedifluoride, polystyrene, polycarbonate, polyethylene, polypropylene,  
30 polyvinyl chloride, poly(methyl acrylate), poly(methyl methacrylate), or combinations thereof. Other substrate materials will be readily apparent to those of ordinary skill in the art upon review of this disclosure. In a preferred embodiment, the substrate is flat glass or single-crystal silicon.

According to some embodiments, the surface of the substrate is etched using well  
35 known techniques to provide for desired surface features. For example, by way of the formation of trenches, v-grooves, mesa structures, raised platforms, or the like, the synthesis regions may be more closely placed within the focus point of impinging light, be provided with reflective "mirror" structures for maximization of light collection from fluorescent sources, or the like.



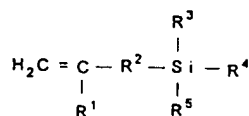
Surfaces on the solid substrate will usually, though not always, be composed of the same material as the substrate. Thus, the surface may be composed of any of a wide variety of materials, for example, polymers, plastics, ceramics, polysaccharides, silica or silica-based materials, carbon, metals, inorganic glasses, membranes, or composites thereof. The surface is functionalized with binding members which are attached firmly to the surface of the substrate. Preferably, the surface functionalities will be reactive groups such as silanol, olefin, amino, hydroxyl, aldehyde, keto, halo, acyl halide, or carboxyl groups. In some cases, such functionalities preexist on the substrate. For example, silica based materials have silanol groups, polysaccharides have hydroxyl groups, and synthetic polymers can contain a broad range of functional groups, depending on which monomers they are produced from. Alternatively, if the substrate does not contain the desired functional groups, such groups can be coupled onto the substrate in one or more steps.

A variety of commercially-available materials, which include suitably modified glass, plastic, or carbohydrate surfaces or a variety of membranes, can be used. Depending on the material, surface functional groups (e.g., silanol, hydroxyl, carboxyl, amino) may be present from the outset (perhaps as part of the coating polymer), or will require a separate procedure (e.g., plasma amination, chromic acid oxidation, treatment with a functionalized side chain alkyltrichlorosilane) for introduction of the functional group. Hydroxyl groups become incorporated into stable carbamate (urethane) linkages by several methods. Amino functions can be acylated directly, whereas carboxyl groups are activated, e.g., with N,N'-carbonyldiimidazole or water-soluble carbodiimides, and reacted with an amino-functionalized compound. As shown in Figure 11, the solid supports can be membranes or surfaces with a starting functional group X. Functional group transformations can be carried out in a variety of ways (as needed) to provide group X\* which represents one partner in the covalent linkage with group Y\*. Figure 11 shows specifically the grafting of PEG (i.e. polyethylene glycol), but the same repertoire of reactions can be used (however needed) to attach carbohydrates (with hydroxyl), linkers (with carboxyl), and/or oligonucleotides that have been extended by suitable functional groups (amino or carboxyl). In some cases, group X\* or Y\* is pre-activated (isolatable species from a separate reaction); alternatively, activation occurs *in situ*. Referring to PEG as drawn in Figure 11, Y and Y\* can be the same (homobifunctional) or different (heterobifunctional); in the latter case, Y can be protected for further control of the chemistry. Unreacted amino groups will be blocked by acetylation or succinylation, to ensure a neutral or negatively charged environment that "repels" excess unhybridized DNA. Loading levels can be determined by standard analytical methods. Fields, et al., "Principles and Practice of Solid-Phase Peptide Synthesis," Synthetic Peptides: A User's Guide, G. Grant, Editor, W.H. Freeman and Co.: New York. p. 77-183 (1992), which is hereby incorporated by reference.

One approach to applying functional groups on a silica-based support surface is to silanize with a molecule either having the desired functional group (e.g., olefin, amino,

- hydroxyl, aldehyde, keto, halo, acyl halide, or carboxyl) or a molecule A able to be coupled to another molecule B containing the desired functional group. In the former case, functionalizing of glass- or silica-based solid supports with, for example, an amino group is carried out by reacting with an amine compound such as 3-aminopropyl
- 5 triethoxysilane, 3-aminopropylmethyldiethoxysilane, 3-aminopropyl dimethylethoxysilane, 3-aminopropyl trimethoxysilane, N-(2-aminoethyl)-3-aminopropylmethyl dimethoxysilane, N-(2-aminoethyl-3-aminopropyl) trimethoxysilane, aminophenyl trimethoxysilane, 4-aminobutyldimethyl methoxysilane, 4-aminobutyl triethoxysilane, aminoethylaminomethyphenethyl trimethoxysilane, or mixtures thereof.
- 10 In the latter case, molecule A preferably contains olefinic groups, such as vinyl, acrylate, methacrylate, or allyl, while molecule B contains olefinic groups and the desired functional groups. In this case, molecules A and B are polymerized together. In some cases, it is desirable to modify the silanized surface to modify its properties (e.g., to impart biocompatibility and to increase mechanical stability). This can be achieved by addition
- 15 of olefinic molecule C along with molecule B to produce a polymer network containing molecules A, B, and C.

Molecule A is defined by the following formula:



20

R<sup>1</sup> is H or CH<sub>3</sub>

R<sup>2</sup> is (C=O)-O-R<sup>6</sup>, aliphatic group with or without functional substituent(s), an aromatic group with or without functional substituent(s), or mixed aliphatic/aromatic groups with or without functional substituent(s);

25

R<sup>3</sup> is an O-alkyl, alkyl, or halogen group;

R<sup>4</sup> is an O-alkyl, alkyl, or halogen group;

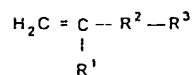
R<sup>5</sup> is an O-alkyl, alkyl, or halogen group; and

R<sup>6</sup> is an aliphatic group with or without functional substituent(s), an aromatic group with or without functional substituent(s), or mixed aliphatic/aromatic groups with or without functional substituent(s). Examples of Molecule A include 3-

30 (trimethoxysilyl)propyl methacrylate, N-[3-(trimethoxysilyl)propyl]-N'-(4-vinylbenzyl)ethylenediamine, triethoxyvinylsilane, triethylvinylsilane, vinyltrichlorosilane, vinyltrimethoxysilane, and vinyltrimethylsilane.

Molecule B can be any monomer containing one or more of the functional groups

35 described above. Molecule B is defined by the following formula:



- (i) R<sup>1</sup> is H or CH<sub>3</sub>,  
 R<sup>2</sup> is (C=O), and  
 R<sup>3</sup> is OH or Cl.

or

- (ii) R<sup>1</sup> is H or CH<sub>3</sub> and  
 R<sup>2</sup> is (C=O)-O-R<sup>4</sup>, an aliphatic group with or without functional  
 substituent(s), an aromatic group with or without functional substituent(s), and mixed  
 aliphatic/aromatic groups with or without functional substituent(s); and  
 R<sup>3</sup> is a functional group, such as OH, COOH, NH<sub>2</sub>, halogen, SH, COCl, or  
 active ester; and  
 R<sup>4</sup> is an aliphatic group with or without functional substituent(s), an  
 aromatic group with or without functional substituent(s), or mixed aliphatic/aromatic  
 groups with or without functional substituent(s). Examples of molecule B include acrylic  
 acid, acrylamide, methacrylic acid, vinylacetic acid, 4-vinylbenzoic acid, itaconic acid,  
 allyl amine, allylethylamine, 4-aminostyrene, 2-aminoethyl methacrylate, acryloyl  
 chloride, methacryloyl chloride, chlorostyrene, dichlorostyrene, 4-hydroxystyrene,  
 hydroxymethyl styrene, vinylbenzyl alcohol, allyl alcohol, 2-hydroxyethyl methacrylate,  
 or poly(ethylene glycol) methacrylate.

Molecule C can be any molecule capable of polymerizing to molecule A, molecule  
 B, or both and may optionally contain one or more of the functional groups described  
 above. Molecule C can be any monomer or cross-linker, such as acrylic acid, methacrylic  
 acid, vinylacetic acid, 4-vinylbenzoic acid, itaconic acid, allyl amine, allylethylamine, 4-  
 aminostyrene, 2-aminoethyl methacrylate, acryloyl chloride, methacryloyl chloride,  
 chlorostyrene, dichlorostyrene, 4-hydroxystyrene, hydroxymethyl styrene, vinylbenzyl  
 alcohol, allyl alcohol, 2-hydroxyethyl methacrylate, poly(ethylene glycol) methacrylate,  
 methyl acrylate, methyl methacrylate, ethyl acrylate, ethyl methacrylate, styrene, 1-  
 vinylimidazole, 2-vinylpyridine, 4-vinylpyridine, divinylbenzene, ethylene glycol  
 dimethacrylate, *N,N'*-methylenediacrylamide, *N,N'*-phenylenediacrylamide, 3,5-  
 bis(acryloylamido)benzoic acid, pentaerythritol triacrylate, trimethylolpropane  
 trimethacrylate, pentaerythritol tetraacrylate, trimethylolpropane ethoxylate (14/3 EO/OH)  
 triacrylate, trimethylolpropane ethoxylate (7/3 EO/OH) triacrylate, triethylolpropane  
 propoxylate (1 PO/OH) triacrylate, or trimethylolpropane propoxylate (2 PO/PH  
 triacrylate).

Generally, the functional groups serve as starting points for oligonucleotides that  
 will ultimately be coupled to the support. These functional groups can be reactive with an  
 organic group that is to be attached to the solid support or it can be modified to be reactive

with that group, as through the use of linkers or handles. The functional groups can also impart various desired properties to the support.

After functionalization (if necessary) of the solid support, tailor-made polymer networks containing activated functional groups that may serve as carrier sites for complementary oligonucleotide capture probes can be grafted to the support. The advantage of this approach is that the loading capacity of capture probes can thus be increased significantly, while physical properties of the intermediate solid-to-liquid phase can be controlled better. Parameters that are subject to optimization include the type and concentration of functional group-containing monomers, as well as the type and relative concentration of the crosslinkers that are used.

The surface of the functionalized substrate is preferably provided with a layer of linker molecules, although it will be understood that the linker molecules are not required elements of the invention. The linker molecules are preferably of sufficient length to permit polymers in a completed substrate to interact freely with molecules exposed to the substrate. The linker molecules should be 6-50 atoms long to provide sufficient exposure. The linker molecules may be, for example, aryl acetylene, ethylene glycol oligomers containing 2-10 monomer units, diamines, diacids, amino acids, or combinations thereof.

According to alternative embodiments, the linker molecules are selected based upon their hydrophilic/hydrophobic properties to improve presentation of synthesized polymers to certain receptors. For example, in the case of a hydrophilic receptor, hydrophilic linker molecules will be preferred to permit the receptor to approach more closely the synthesized polymer.

According to another alternative embodiment, linker molecules are also provided with a photocleavable group at any intermediate position. The photocleavable group is preferably cleavable at a wavelength different from the protective group. This enables removal of the various polymers following completion of the syntheses by way of exposure to the different wavelengths of light.

The linker molecules can be attached to the substrate via carbon-carbon bonds using, for example, (poly)tri-fluorochloroethylene surfaces or, preferably, by siloxane bonds (using, for example, glass or silicon oxide surfaces). Siloxane bonds with the surface of the substrate may be formed in one embodiment via reactions of linker molecules bearing trichlorosilyl groups. The linker molecules may optionally be attached in an ordered array, i.e., as parts of the head groups in a polymerized monolayer. In alternative embodiments, the linker molecules are adsorbed to the surface of the substrate.

It is often desirable to introduce a PEG spacer with complementary functionalization, prior to attachment of the starting linker for DNA or PNA synthesis. G. Barany, et al., "Novel Polyethylene Glycol-polystyrene (PEG-PS) Graft Supports for Solid-phase Peptide Synthesis," ed. C.H. Schneider and A.N. Eberle., Leiden, The Netherlands: Escom Science Publishers. 267-268 (1993); Zalipsky, et al., "Preparation and Applications of Polyethylene Glycol-polystyrene Graft Resin Supports for Solid-phase

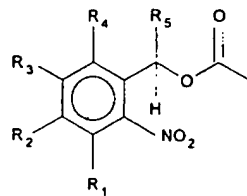
Peptide Synthesis," Reactive Polymers, 22:243-58 (1994); J.M. Harris, ed. "Poly(Ethylene Glycol) Chemistry: Biotechnical and Biomedical Applications," (1992), Plenum Press: New York, which are hereby incorporated by reference. Similarly, dextran layers can be introduced as needed. Cass, et al., "Pilot, A New Peptide Lead Optimization Technique and Its Application as a General Library Method, in Peptides - Chemistry, Structure and Biology: Proceedings of the Thirteenth American Peptide Symposium", R.S. Hodges and J.A. Smith, Editor. (1994), Escom: Leiden, The Netherlands; Lofas, et al., "A Novel Hydrogel Matrix on Gold Surface Plasma Resonance Sensors for Fast and Efficient Covalent Immobilization of Ligands," J. Chem. Soc., Chem. Commun., pp. 1526-1528 (1990), which are hereby incorporated by reference. Particularly preferred linkers are tris(alkoxy)benzyl carbonium ions with dilute acid due to their efficient and specific trapping with indole moieties. DNA oligonucleotides can be synthesized and terminated with a residue of the amino acid tryptophan, and conjugated efficiently to supports that have been modified by tris(alkoxy)benzyl ester (hypersensitive acid labile ("HAL")) or tris(alkoxy)benzylamide ("PAL") linkers [F. Albericio, et al., J. Org. Chem., 55:3730-3743 (1990); F. Albericio and G. Barany, Tetrahedron Lett., 32:1015-1018 (1991)], which are hereby incorporated by reference). Other potentially rapid chemistries involve reaction of thiols with bromoacetyl or maleimido functions. In one variation, the terminus of amino functionalized DNA is modified by bromoacetic anhydride, and the bromoacetyl function is captured by readily established thiol groups on the support. Alternatively, an N-acetyl, S-tritylcysteine residue coupled to the end of the probe provides, after cleavage and deprotection, a free thiol which can be captured by a maleimido group on the support. As shown in Figure 12, chemically synthesized probes can be extended, on either end. Further variations of the proposed chemistries are readily envisaged. Figure 12A shows that an amino group on the probe is modified by bromoacetic anhydride; the bromoacetyl function is captured by a thiol group on the support. Figure 12B shows that an N-acetyl, S-tritylcysteine residue coupled to the end of the probe provides, after cleavage and deprotection, a free thiol which is captured by a maleimido group on the support. Figure 12C shows a probe containing an oligo-tryptophanyl tail ( $n = 1$  to 3), which is captured after treatment of a HAL-modified solid support with dilute acid.

To prepare the arrays of the present invention, the solid supports must be charged with DNA oligonucleotides or PNA oligomers. This is achieved either by attachment of pre-synthesized probes, or by direct assembly and side-chain deprotection (without release of the oligomer) onto the support. Further, the support environment needs to be such as to allow efficient hybridization. Toward this end, two factors may be identified: (i) sufficient hydrophilic character of support material (e.g., PEG or carbohydrate moieties) and (ii) flexible linker arms (e.g., hexaethylene oxide or longer PEG chains) separating the probe from the support backbone. It should be kept in mind that numerous ostensibly "flat surfaces" are quite thick at the molecular level. Lastly, it is important that the support

material not provide significant background signal due to non-specific binding or intrinsic fluorescence.

The linker molecules and monomers used herein are provided with a functional group to which is bound a protective group. Preferably, the protective group is on the distal or terminal end of the linker molecule opposite the substrate. The protective group may be either a negative protective group (i.e., the protective group renders the linker molecules less reactive with a monomer upon exposure) or a positive protective group (i.e., the protective group renders the linker molecules more reactive with a monomer upon exposure). In the case of negative protective groups, an additional step of reactivation will be required. In some embodiments, this will be done by heating.

The protective group on the linker molecules may be selected from a wide variety of positive light-reactive groups preferably including nitro aromatic compounds such as o-nitrobenzyl derivatives or benzylsulfonyl. In a preferred embodiment, 6-nitroveratryloxycarbonyl ("NVOC"), 2-nitrobenzyloxycarbonyl ("NBOC"), Benzyloxycarbonyl ("BOC"), fluorenylmethoxycarbonyl ("Fmoc"), or  $\alpha,\alpha$ -dimethyl-dimethoxybenzyloxycarbonyl ("DDZ") is used. In one embodiment, a nitro aromatic compound containing a benzylic hydrogen ortho to the nitro group is used, i.e., a chemical of the form:



20

where R<sub>1</sub> is alkoxy, alkyl, halo, aryl, alkenyl, or hydrogen; R<sub>2</sub> is alkoxy, alkyl, halo, aryl, nitro, or hydrogen; R<sub>3</sub> is alkoxy, alkyl, halo, nitro, aryl, or hydrogen; R<sub>4</sub> is alkoxy, alkyl, hydrogen, aryl, halo, or nitro; and R<sub>5</sub> is alkyl, alkynyl, cyano, alkoxy, hydrogen, halo, aryl, or alkenyl. Other materials which may be used include o-hydroxy- $\alpha$ -methyl cinnamoyl derivatives. Photoremovable protective groups are described in, for example, Patchornik, *J. Am. Chem. Soc.* 92:6333 (1970) and Amit et al., *J. Org. Chem.* 39:192 (1974), both of which are hereby incorporated by reference.

In an alternative embodiment, the positive reactive group is activated for reaction with reagents in solution. For example, a 5-bromo-7-nitro indoline group, when bound to a carbonyl, undergoes reaction upon exposure to light at 420 nm.

In a second alternative embodiment, the reactive group on the linker molecule is selected from a wide variety of negative light-reactive groups including a cinnamate group.

30

Alternatively, the reactive group is activated or deactivated by electron beam lithography, x-ray lithography, or any other radiation. A suitable reactive group for electron beam lithography is a sulfonyl group. Other methods may be used including, for example, exposure to a current source. Other reactive groups and methods of activation  
5 may be used in view of this disclosure.

The linking molecules are preferably exposed to, for example, light through a suitable mask using photolithographic techniques of the type known in the semiconductor industry and described in, for example, Sze, *VLSI Technology*, McGraw-Hill (1983), and Mead et al., *Introduction to VLSI Systems*, Addison-Wesley (1980), which are hereby  
10 incorporated by reference for all purposes. The light may be directed at either the surface containing the protective groups or at the back of the substrate, so long as the substrate is transparent to the wavelength of light needed for removal of the protective groups.

The mask is in one embodiment a transparent support material selectively coated with a layer of opaque material. Portions of the opaque material are removed, leaving  
15 opaque material in the precise pattern desired on the substrate surface. The mask is brought directly into contact with the substrate surface. "Openings" in the mask correspond to locations on the substrate where it is desired to remove photoremovable protective groups from the substrate. Alignment may be performed using conventional alignment techniques in which alignment marks are used accurately to overlay successive  
20 masks with previous patterning steps, or more sophisticated techniques may be used. For example, interferometric techniques such as the one described in Flanders et al., "A New Interferometric Alignment Technique." *App. Phys. Lett.* 31:426-428 (1977), which is hereby incorporated by reference, may be used.

To enhance contrast of light applied to the substrate, it is desirable to provide  
25 contrast enhancement materials between the mask and the substrate according to some embodiments. This contrast enhancement layer may comprise a molecule which is decomposed by light such as quinone diazide or a material which is transiently bleached at the wavelength of interest. Transient bleaching of materials will allow greater penetration where light is applied, thereby enhancing contrast. Alternatively, contrast enhancement  
30 may be provided by way of a cladded fiber optic bundle.

The light may be from a conventional incandescent source, a laser, a laser diode, or the like. If non-collimated sources of light are used, it may be desirable to provide a thick- or multi-layered mask to prevent spreading of the light onto the substrate. It may, further,  
35 be desirable in some embodiments to utilize groups which are sensitive to different wavelengths to control synthesis. For example, by using groups which are sensitive to different wavelengths, it is possible to select branch positions in the synthesis of a polymer or eliminate certain masking steps.

Alternatively, the substrate may be translated under a modulated laser or diode light source. Such techniques are discussed in, for example, U.S. Patent No. 4,719,615 to  
40 Feyrer et al., which is hereby incorporated by reference. In alternative embodiments, a

laser galvanometric scanner is utilized. In other embodiments, the synthesis may take place on or in contact with a conventional liquid crystal (referred to herein as a "light valve") or fiber optic light sources. By appropriately modulating liquid crystals, light may be selectively controlled to permit light to contact selected regions of the substrate.

5 Alternatively, synthesis may take place on the end of a series of optical fibers to which light is selectively applied. Other means of controlling the location of light exposure will be apparent to those of skill in the art.

The development of linkers and handles for peptide synthesis is described in Fields, et al., "Principles and Practice of Solid-Phase Peptide Synthesis," Synthetic Peptides: A User's Guide, G. Grant, Editor. W.H. Freeman and Co.: New York. p. 77-183  
10 (1992); G. Barany, et al., "Recent Progress on Handles and Supports for Solid-phase Peptide Synthesis", Peptides-Chemistry, Structure and Biology: Proceedings of the Thirteenth American Peptide Symposium, R.S. Hodges and J.A. Smith, Editor. Escom Science Publishers: Leiden, The Netherlands pp.1078-80 (1994), which are hereby  
15 incorporated by reference. This technology is readily extendable to DNA and PNA. Of particular interest is the development of PAL (Albericio, et al., "Preparation and Application of the 5-(4-(9-Fluorenylmethyloxycarbonyl)Aminomethyl-3,5-Dimethoxyphenoxy)Valeric Acid (PAL) Handle for the Solid-phase Synthesis of C-terminal Peptide Amides under Mild Conditions," J. Org. Chem., 55:3730-3743 (1990),  
20 which is hereby incorporated by reference, and ester (HAL) (Albericio, et al., "Hypersensitive Acid-labile (HAL) Tris(alkoxy)Benzyl Ester Anchoring for Solid-phase Synthesis of Protected Peptide Segments," Tetrahedron Lett., 32:1015-1018 (1991), which is hereby incorporated by reference, linkages, which upon cleavage with acid provide, respectively, C-terminal peptide amides, and *protected* peptide acids that can be used as  
25 building blocks for so-called *segment condensation* approaches. The stabilized carbonium ion generated in acid from cleavage of PAL or HAL linkages can be intercepted by tryptophanyl-peptides. While this reaction is a nuisance for peptide synthesis and preventable (in part) by use of appropriate scavengers, it has the positive application of chemically capturing oligo-Trp-end-labelled DNA and PNA molecules by HAL-modified  
30 surfaces.

The art recognizes several approaches to making oligonucleotide arrays. Southern, et al., "Analyzing and Comparing Nucleic Acid Sequences by Hybridization to Arrays of Oligonucleotides: Evaluation using Experimental Models," Genomics, 13:1008-1017  
(1992); Fodor, et al., "Multiplexed Biochemical Assays with Biological Chips," Nature,  
35 364:555-556 (1993); Khrapko, et al., "A Method for DNA Sequencing by Hybridization with Oligonucleotide Matrix," J. DNA Seq. Map., 1:375-388 (1991); Van Ness, et al., "A Versatile Solid Support System for Oligodeoxynucleoside Probe-based Hybridization Assays," Nucleic Acids Res., 19:3345-3350 (1991); Zhang, et al., "Single-base Mutational Analysis of Cancer and Genetic Diseases Using Membrane Bound Modified  
40 Oligonucleotides," Nucleic Acids Res., 19:3929-3933 (1991); K. Beattie, "Advances in



Genosensor Research," Clin. Chem. 41(5):700-06 (1995), which are hereby incorporated by reference. These approaches may be divided into three categories: (i) Synthesis of oligonucleotides by standard methods and their attachment one at a time in a spatial array; (ii) Photolithographic masking and photochemical deprotection on a silicon chip, to allow for synthesis of short oligonucleotides (Fodor, et al., "Multiplexed Biochemical Assays with Biological Chips," Nature, 364:555-556 (1993) and R.J. Lipshutz, et al., "Using Oligonucleotide Probe Arrays To Assess Genetic Diversity," Biotechniques 19:442-447 (1995), which are hereby incorporated by reference); and (iii) Physical masking to allow for synthesis of short oligonucleotides by addition of single bases at the unmasked areas (Southern, et al., "Analyzing and Comparing Nucleic Acid Sequences by Hybridization to Arrays of Oligonucleotides: Evaluation Using Experimental Models," Genomics, 13:1008-1017 (1992); Maskos, et al., "A Study of Oligonucleotide Reassociation Using Large Arrays of Oligonucleotides Synthesized on a Glass Support," Nucleic Acids Res., 21:4663-4669 (1993), which are hereby incorporated by reference).

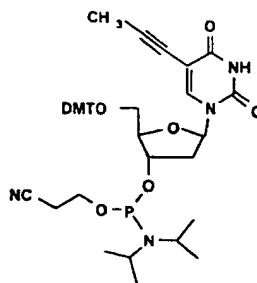
Although considerable progress has been made in constructing oligonucleotide arrays, some containing as many as 256 independent addresses, these procedures are less preferred, for detecting specific DNA sequences by hybridizations. More particularly, arrays containing longer oligonucleotides can currently be synthesized only by attaching one address at a time and, thus, are limited in potential size. Current methods for serially attaching an oligonucleotide take about 1 hour, thus an array of 1,000 addresses would require over 40 days of around-the-clock work to prepare. Arrays containing short oligonucleotides of 8- to 10- mers do not have commercial applicability, because longer molecules are needed to detect single base differences effectively.

These prior procedures may still be useful to prepare said supports carrying an array of oligonucleotides for the method of detection of the present invention. However, there are more preferred approaches.

It is desirable to produce a solid support with a good loading of oligonucleotide or PNA oligomer in a relatively small, but well-defined area. Current, commercially available fluorescent imagers can detect a signal as low as 3 attomoles per 50 $\mu$ m square pixel. Thus, a reasonable size address or "spot" on an array would be about 4 x 4 pixels, or 200 $\mu$ m square. Smaller addresses could be used with CCD detection. The limit of detection for such an address would be about 48 attomoles per "spot", which is comparable to the 100 attomole detection limit using a fluorescent DNA sequencing machine. The capacity of oligonucleotides which can be loaded per 200 $\mu$ m square will give an indication of the potential signal to noise ratio. A loading of 20 fmoles would give a signal to noise ratio of about 400 to 1, while 200 fmoles would allow for a superb signal to noise ratio of about 4000 to 1. The oligonucleotide or PNA oligomer should be on a flexible "linker arm" and on the "outside" or "surface" of the solid support for easier hybridizations. The support should be non-fluorescent, and should not interfere with hybridization nor give a high background signal due to nonspecific binding.

The complementary capture oligonucleotide addresses on the solid supports can be either DNA or PNA. PNA-based capture is preferred over DNA-based capture, because PNA/DNA duplexes are much stronger than DNA/DNA duplexes, by about 1°C/base-pair. M. Egholm, et al., "PNA Hybridizes to Complementary Oligonucleotides Obeying the Watson-Crick Hydrogen-bonding Rules," *Nature*, 365:566-568 (1993), which is hereby incorporated by reference. Thus, for a 24-mer DNA/DNA duplex with  $T_m = 72^\circ\text{C}$ , the corresponding duplex with one PNA strand would have a "predicted"  $T_m = 96^\circ\text{C}$  (the actual melting point might be slightly lower as the above "rule of thumb" is less accurate as melting points get over  $80^\circ\text{C}$ ). Additionally, the melting difference between DNA/DNA and PNA/DNA becomes even more striking at low salt.

The melting temperature of DNA/DNA duplexes can be estimated as  $[4n(\text{G}\cdot\text{C}) + 2m(\text{A}\cdot\text{T})]^\circ\text{C}$ . Oligonucleotide capture can be optimized by narrowing the  $T_m$  difference between duplexes formed by capture oligonucleotides and the complementary addressable array-specific portions hybridized to one another resulting from differences in G•C/A•T content. Using 5-propynyl-dU in place of thymine increases the  $T_m$  of DNA duplexes an average of 1.7°C per substitution. Froehler, et al., "Oligonucleotides Containing C-5 Propyne Analogs of 2'-deoxyuridine and 2'-deoxycytidine," *Tetrahedron Lett.*, 33:5307-5310 (1992) and J. Sagi, et al., *Tetrahedron Letters*, 34:2191 (1993), which are hereby incorporated by reference. The same substitution in the capture scheme should lower the  $T_m$  difference between the components of such duplexes and raise the  $T_m$  for all of the duplexes. Phosphoramidite derivatives of 5-propynyl-dU having the following structure can be prepared according to the immediately preceding Froehler and Sagi references, which are hereby incorporated by reference.

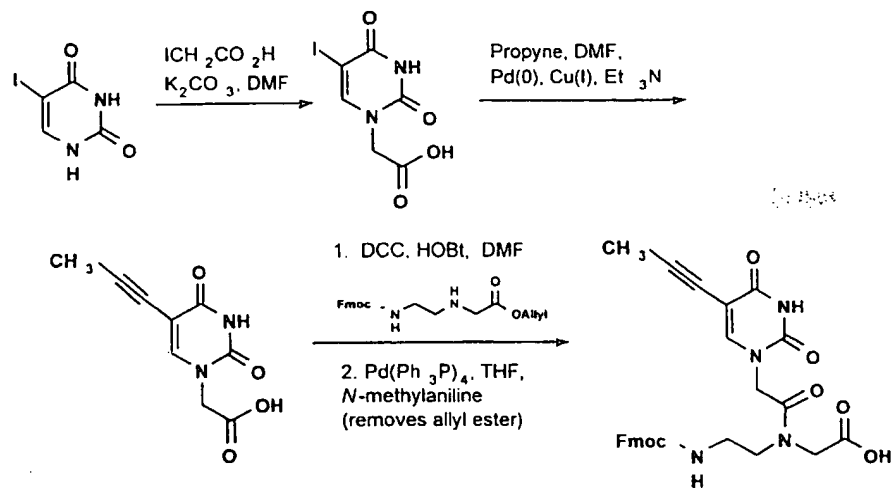


25

The 5-propynyluracil PNA monomer with Fmoc amino protection can be made by the following synthesis (where DMF is N,N'-dimethylformamide, DCC is N,N'-dicyclohexylcarbodiimide, HOBt is 1-hydroxybenzotriazole, and THF is tetrahydrofuran):

30

35



Using the methods described by Egholm, et al., "Peptide Nucleic Acids (PNA).

- 5 Oligonucleotide Analogues with an Achiral Peptide Backbone," *J. Am. Chem. Soc.*, 114:1895-1897 (1992) and Egholm, et al., "Recognition of Guanine and Adenine in DNA by Cytosine and Thymine Containing Peptide Nucleic Acids (PNA)," *J. Am. Chem. Soc.*, 114:9677-9678 (1992), which are hereby incorporated by reference. The synthesis scheme above describes the preparation of a PNA monomer having a 5-propynyl-uracil base
- 10 component. 5-Iodouracil is first alkylated with iodoacetic acid, and, then, the propynyl group is coupled to the base moiety by a Pd/Cu catalyst. The remaining steps in the scheme follow from the above-referenced methods. These monomers can be incorporated into synthetic DNA and PNA strands.

- 15 There are two preferred general approaches for synthesizing arrays. In the first approach, full-length DNA oligonucleotides or PNA oligomers are prepared and are subsequently linked covalently to a solid support or membrane. In the second approach, specially designed PNA oligomers or DNA oligonucleotides are constructed by sequentially adding multimers to the solid support. These multimers are added to specific rows or columns on a solid support or membrane surface. The resulting "checkerboard"
- 20 pattern generates unique addressable arrays of full length PNA or DNA.

Figures 14-16 show different modes of preparing full-length DNA oligonucleotides or PNA oligomers and, subsequently, linking those full length molecules to the solid support.

- 25 Figures 14A-E depict a method for constructing an array of DNA or PNA oligonucleotides by coupling individual full-length oligonucleotides to the appropriate locations in a grid. The array of Figure 14A shows the pattern of oligonucleotides that would be generated if oligonucleotides are coupled to sixteen  $200\mu\text{m} \times 200\mu\text{m}$  regions of the array surface. Each individual  $200\mu\text{m} \times 200\mu\text{m}$  region contains DNA or PNA with a

unique sequence which is coupled to the surface. The individual square regions will be separated from adjacent squares by  $200\mu\text{m}$ . The array of Figure 14A can thus support 64 ( $8 \times 8$ ) different oligonucleotides in a 3 mm by 3 mm area. In order to multiplex the construction of the array, 16 squares separated by a distance of  $800\mu\text{m}$  will be coupled simultaneously to their specific oligonucleotides. Therefore, the  $8 \times 8$  grid could be constructed with only 4 machine steps as shown in Figures 14B-14E. In these diagrams, the dark squares represent locations that are being altered in the current synthesis step, while the hatched squares represent regions which have been synthesized in earlier steps. The first step (Figure 14B) would immobilize oligonucleotides at locations A1, E1, I1, M1, A5, E5, I5, M5, A9, E9, I9, M9, A13, E13, I13, and M13 simultaneously. In the next step (Figure 14C), the machine would be realigned to start in Column C. After having completed Row 1, the next step (Figure 14D) would start at Row 3. Finally, the last 16 oligonucleotides would be immobilized in order to complete the  $8 \times 8$  grid (Figure 14E). Thus, the construction of the  $8 \times 8$  array could be reduced to 4 synthesis steps instead of 64 individual spotting reactions. This method would be easily extended and an apparatus capable of spotting 96 oligomers simultaneously could be used rapidly to construct larger arrays.

Figures 15A-E represent a perspective dimensional view of the array construction process described in Figure 14. In Figures 15A-E, the construction of a  $4 \times 4$  (16) array using a machine capable of spotting four different 24-mers simultaneously is depicted. First, as shown in Figure 15A, the machine attaches 4 oligomers at locations A1, E1, A5, and E5. Next, as shown in Figure 15B, the machine is shifted horizontally and attaches 4 oligomers at locations C1, G1, C5, and G5. Next, as shown in Figure 15C, the machine is repositioned and attaches 4 oligomers at locations A3, E3, A7, and E7. Finally, as shown in Figure 15D, the machine attaches the 4 remaining oligomers at positions C3, G3, C7, and G7. The completed array contains sixteen 24-mers as shown in the perspective view of Figure 15E.

Figures 16A-C show views for an application apparatus 2 capable of simultaneously coupling 16 different oligonucleotides to different positions on an array grid G as shown in Figure 14. The black squares in the top view (Figure 16A) represent sixteen  $200\mu\text{m} \times 200\mu\text{m}$  regions that are spatially separated from each other by  $600\mu\text{m}$ . The apparatus shown has 16 input ports which would allow tubes containing different oligonucleotides to fill the funnel-shaped chambers above different locations on the array. The side views (Figures 16B-C, taken along lines 16B-16B and 16C-16C, of Figure 16A, respectively) of the apparatus demonstrate that funnel shaped chambers 4 align with the appropriate region on the array below the apparatus. In addition, two valves 6 and 8 (hatched squares in Figures 16A-C) control the flow of fluid in the 16 independent reaction chambers. One valve 6 controls the entry of fluids from the input port 10, while the other valve 8 would be attached to a vacuum line 12 in order to allow loading and clearing of the reaction chamber 4. The apparatus would first be aligned over the

appropriate  $200\mu\text{m} \times 200\mu\text{m}$  regions of the array. Next, the entire apparatus is firmly pressed against the array, thus forming a closed reaction chamber above each location. The presence of raised  $10\mu\text{m}$  ridges R around each location on the array ensures the formation of a tight seal which would prevent leakage of oligomers to adjacent regions on the array. Next, the valve 8 to vacuum line 12 would be opened, while the valve 10 from the input solution port 10 would be closed. This would remove air from the reaction chamber 4 and would create a negative pressure in the chamber. Then, the valve 8 to vacuum line 12 would be closed and the valve 10 from the input solution port 10 would be opened. The solution would flow into the reaction chamber 4 due to negative pressure. This process eliminates the possibility of an air bubble forming within the reaction chamber 4 and ensures even distribution of oligonucleotides across the  $200\mu\text{m} \times 200\mu\text{m}$  region. After the oligonucleotides have been coupled to the activated array surface, the input valve 6 would be closed, the valve 8 to vacuum line 12 would be opened, and the apparatus would be lifted from the array surface in order to remove completely any excess solution from the reaction chamber. A second apparatus can now be realigned for the synthesis of the next 16 locations on the array.

Figures 15 to 26 show different modes of constructing PNA oligomers or DNA oligonucleotides on a solid support by sequentially adding, respectively, PNA or DNA, multimers to the solid support.

As an example of assembling arrays with multimers, such assembly can be achieved with tetramers. Of the  $256 (4^4)$  possible ways in which four bases can be arranged as tetramers, 36 that have unique sequences can be selected. Each of the chosen tetramers differs from all the others by at least two bases, and no two dimers are complementary to each other. Furthermore, tetramers that would result in self-pairing or hairpin formation of the addresses have been eliminated.

The final tetramers are listed in Table 1 and have been numbered arbitrarily from 1 to 36. This unique set of tetramers are used as design modules for the sometimes desired 24-mer capture oligonucleotide address sequences. The structures can be assembled by stepwise (one base at a time) or convergent (tetramer building blocks) synthetic strategies. Many other sets of tetramers may be designed which follow the above rules. The segment approach is not uniquely limited to tetramers, and other units, i.e. dimers, trimers, pentamers, or hexamers could also be used.

**Table 1. List of tetramer PNA sequences and complementary DNA sequences, which differ from each other by at least 2 bases.**

Number	Sequence (N-C)	Complement (5'-3')	G + C
1.	TCTG	CAGA	2
2.	TGTC	GACA	2
3.	TCCC	GGGA	3
4.	TGCG	CGCA	3
5.	TCGT	ACGA	2
6.	TTGA	TCAA	1
7.	TGAT	ATCA	1
8.	TTAG	CTAA	1
9.	CTTG	CAAG	2
10.	CGTT	AACG	2
11.	CTCA	TGAG	2
12.	CACG	CGTG	3
13.	CTGT	ACAG	2
14.	CAGC	GCTG	3
15.	CCAT	ATGG	2
16.	CGAA	TTCG	2
17.	GCTT	AAGC	2
18.	GGTA	TACC	2
19.	GTCT	AGAC	2
20.	GACC	GGTC	3
21.	GAGT	ACTC	2
22.	GTGC	GCAC	3
23.	GCAA	TTGC	2
24.	GGAC	GTCC	3
25.	AGTG	CACT	2
26.	AATC	GATT	1
27.	ACCT	AGGT	2
28.	ATCG	CGAT	2
29.	ACGG	CCGT	3
30.	AGGA	TCCT	2
31.	ATAC	GTAT	1
32.	AAAG	CTTT	1
33.	CCTA	TAGG	2
34.	GATG	CATC	2
35.	AGCC	GGCT	3
36.	TACA	TGTA	1

5

Note that the numbering scheme for tetramers permits abbreviation of each address as a string of six numbers (e.g., second column of Table 2 *infra*). The concept of a 24-mer address designed from a unique set of 36 tetramers (Table 1) allows a huge number of possible structures,  $36^6 = 2,176,782,336$ .

10

Figure 17 shows one of the many possible designs of 36 tetramers which differ from each other by at least 2 bases. The checkerboard pattern shows all 256 possible tetramers. A given square represents the first two bases on the left followed by the two bases on the top of the checkerboard. Each tetramer must differ from each other by at least two bases, and should be non-complementary. The tetramers are shown in the white

15

boxes, while their complements are listed as (number)'. Thus, the complementary

sequences GACC (20) and GGTC (20') are mutually exclusive in this scheme. In addition, tetramers must be non-palindromic, e.g., TCGA (darker diagonal line boxes), and non-repetitive, e.g., CACA (darker diagonal line boxes from upper left to lower right). All other sequences which differ from the 36 tetramers by only 1 base are shaded in light gray.

- 5 Four potential tetramers (white box) were not chosen as they are either all A•T or G•C bases. However, as shown below, the  $T_m$  values of A•T bases can be raised to almost the level of G•C bases. Thus, all A•T or G•C base tetramers (including the ones in white boxes) could potentially be used in a tetramer design. In addition, thymine can be replaced by 5-propynyl uridine when used within capture oligonucleotide address
- 10 sequences as well as in the oligonucleotide probe addressable array-specific portions. This would increase the  $T_m$  of an A•T base pair by  $\sim 1.7^\circ\text{C}$ . Thus,  $T_m$  values of individual tetramers should be approximately  $15.1^\circ\text{C}$  to  $15.7^\circ\text{C}$ .  $T_m$  values for the full length 24-mers should be  $95^\circ\text{C}$  or higher.

- To illustrate the concept, a subset of six of the 36 tetramer sequences were used to
- 15 construct arrays: 1 = TGCG; 2 = ATCG; 3 = CAGC; 4 = GGTA; 5 = GACC; and 6 = ACCT. This unique set of tetramers can be used as design modules for the required 24-mer addressable array-specific portion and 24-mer complementary capture oligonucleotide address sequences. This embodiment involves synthesis of five addressable array-specific
- 20 portion (sequences listed in Table 2). Note that the numbering scheme for tetramers allows abbreviation of each portion (referred to as "Zip #") as a string of six numbers (referred to as "zip code").

**Table 2. List of all 5 DNA/PNA oligonucleotide address sequences.**

25

Zip #	Zip code	Sequence (5' → 3' or NH <sub>2</sub> → COOH)	G+C
Zip11	1-4-3-6-6-1	TGCG-GGTA-CAGC-ACCT-ACCT-TGCG	15
Zip12	2-4-4-6-1-1	ATCG-GGTA-GGTA-ACCT-TGCG-TGCG	14
Zip13	3-4-5-6-2-1	CAGC-GGTA-GACC-ACCT-ATCG-TGCG	15
Zip14	4-4-6-6-3-1	GGTA-GGTA-ACCT-ACCT-CAGC-TGCG	14
Zip15	5-4-1-6-4-1	GACC-GGTA-TGCG-ACCT-GGTA-TGCG	15

- Each of these oligomers contains a hexaethylene oxide linker arm on their 5' termini [P. Grossman, et al., *Nucl. Acids Res.*, 22:4527-4534 (1994), which is hereby incorporated by
- 30 reference], and ultimate amino-functions suitable for attachment onto the surfaces of glass slides, or alternative materials. Conjugation methods will depend on the free surface functional groups [Y. Zhang, et al., *Nucleic Acids Res.*, 19:3929-3933 (1991) and Z. Guo, et al., *Nucleic Acids Res.*, 34:5456-5465 (1994), which are hereby incorporated by reference].

- 35 Synthetic oligonucleotides (normal and complementary directions, either for capture hybridization or hybridization/ligation) are prepared as either DNA or PNA, with either natural bases or nucleotide analogues. Such analogues pair with perfect complementarity to the natural bases but increase  $T_m$  values (e.g., 5-propynyl-uracil).

Each of the capture oligonucleotides have substantial sequence differences to minimize any chances of cross-reactivity -- see Figure 17 and Table 1. Rather than carrying out stepwise synthesis to introduce bases one at a time, protected PNA tetramers can be used as building blocks. These are easy to prepare; the corresponding protected oligonucleotide intermediates require additional protection of the internucleotide phosphate linkages. Construction of the 24-mer at any given address requires only six synthetic steps with a likely improvement in overall yield by comparison to stepwise synthesis. This approach eliminates totally the presence of failure sequences on the support, which could occur when monomers are added one-at-a-time to the surface. Hence, in contrast to previous technologies, the possibilities for false signals are reduced. Moreover, since failure sequences at each address are shorter and lacking at least four bases, there is no risk that these will interfere with correct hybridization or lead to incorrect hybridizations. This insight also means that "capping" steps will not be necessary.

Masking technology will allow several addresses to be built up simultaneously, as is explained below. As direct consequences of the manufacturing process for the arrays, several further advantages are noted. Each 24-mer address differs from its nearest 24-mer neighbor by three tetramers, or at least 6 bases. At low salt, each base mismatch in PNA/DNA hybrids decreases the melting temperature by 8°C. Thus, the  $T_m$  for the correct PNA/DNA hybridization is at least 48°C higher than any incorrect hybridization. Also, neighboring 24-mers are separated by 12-mers, which do not hybridize with anything and represent "dead" zones in the detection profile. PNA addresses yield rugged, reusable arrays.

The following description discloses the preparation of 36 unique PNA tetramers and shows the mechanical/chemical strategy to prepare the arrays. This technique can be used to create a 5x5 array with 25 addresses of PNA 24-mers. Alternatively, all 36 tetramers can be incorporated to generate full-size arrays of 1,296 addresses.

Figures 18A-G are schematic diagrams showing addition of PNA tetramers to generate a 5x5 array of unique 24 mer addresses. The manufacturing device is able to add PNA tetramers in either columns, or in rows, by rotating the multi-chamber device or surface 90°. A circular manifold allows circular permutation of tetramer addition. Thus, complex unique addresses may be built by using a simple algorithm. In the first tetramer addition, PNA tetramers 1, 2, 3, 4, and 5 are linked to the surface in each of the 5 columns, respectively as shown in Figure 18A. After rotating the chamber 90°, PNA tetramers 6, 5, 4, 3, and 2 are added in adjacent rows, as shown in Figure 18B. In the third step, as shown in Figure 18C, tetramers 3, 4, 5, 6, and 1 (note circular permutation) are added in columns. In the 4th step, as shown in Figure 18D, tetramers 2, 1, 6, 5, and 4 are added in adjacent rows, etc. This process continues in the manner shown in Figure 23E-G described *infra*. The bottom of the diagram depicts tetramer sequences which generate unique 24 mers at each position. The middle row of sequences 1-4-3-6-6-1; 2-4-4-6-1-1; 3-4-5-6-2-1; 4-4-6-



6-3 and 5-4-1-6-4-1 are shown in full length in Table 2. The addition of tetramers in a circularly permuted fashion can be used to generate larger arrays. Tetramer addition need not be limited to circular patterns and can be added in many other combinations to form unique addresses which differ from each other by at least 3 tetramers, which translates to at least 6 bases.

The present invention has greater specificity than existing mutation detection methods which use allele-specific PCR, differential hybridization, or sequencing-by-hybridization. These methods rely on hybridization alone to distinguish single-base differences in two otherwise identical oligonucleotides. The signal-to-noise ratios for such hybridization are markedly lower than those that can be achieved even with the two most closely-related capture oligonucleotides in an array. Since each address is designed by alternating tetramer addition in three rows and three columns, a given address will differ by at least three tetramers from its neighbor. Since each tetramer differs from every other tetramer by at least 2 bases, a given address will differ from another address by at least 6 bases. However, in practice, most addresses will differ from most other addresses by considerably more bases.

This concept is illustrated below using the two addresses, Zip 12 and Zip 14. These two addresses are the most related among the 25 addresses schematically represented in Figures 18 and 20 (discussed *infra*). These two addresses have in common tetramers on every alternating position (shown as underlined):

Zip 12 (2-4-4-6-1-1) = 24 mer  
 5' - ATCG GGTA GGTA ACCT TGCG TGCG-3'  
 Zip 14 (4-4-6-6-3-1) = 24 mer  
 5' - GGTA GGTA ACCT ACCT CAGC TGCG-3'

In addition, they have in common a string of 12 nucleotides, as well as the last four in common (shown as underlined):

Zip 12 (2-4-4-6-1-1) = 24 mer  
 5' - ATCG GGTA GGTA ACCT TGCG TGCG-3'  
 Zip 14 (4-4-6-6-3-1) = 24 mer  
 5' - GGTA GGTA ACCT ACCT CAGC TGCG-3'

Either representation has at least 8 differences between the oligonucleotides. Although an oligonucleotide complementary to Zip 12 or Zip 14 at the underlined nucleotides could hybridize to both of these addresses at a lower temperature (e.g., 37°C), only the fully complementary oligonucleotide would hybridize at elevated temperature (e.g., 70°C).

Furthermore, for other capture oligonucleotides, such as Zip 3, the number of shared nucleotides is much lower (shown as underlined):

Zip 12 (2-4-4-6-1-1) = 24 mer

5 5' - ATCG GGTA QGTA ACCT TGCG TGCG-3'

Zip 3 (3-6-5-2-2-3) = 24 mer

5' - CAGC ACCT GACC ATCG ATCG CAGC-3'

Therefore, the ability to discriminate Zip 12 from Zip 3 during hybridization is significantly greater than can be achieved using any of the existing methods.

A multi-chamber device with alternating chambers and walls (each 200µm thick) will be pressed onto the modified glass or silicon surface of Figure 19A prior to delivery of PNA tetramers into either columns or rows. The surface will be etched to produce 10µm ridges (black lines) to eliminate leaking between chambers. Initially, a flexible spacer (linker) is attached to the array surface. In the first step, as shown in Figure 19B, PNA tetramers, 1, 2, 3, 4, and 5 are linked to the surface in each of the five columns, respectively. The multi-chamber device is then rotated 90°. Tetramers 6, 5, 4, 3, and 2 are added in adjacent rows, as shown in Figure 19C. The process is repeated a total of three times to synthesize 24-mer PNA oligomers. Each completed 24-mer within a given row and column represents a unique PNA sequence, hence achieving the desired addressable array. Smaller oligonucleotide sequences represent half-size 12-mers which result from 3 rounds of synthesis in the same direction. Since each 24-mer differs from its neighbor by three tetramers and each tetramer differs from another by at least 2 bases, then each 24-mer differs from the next by at least 6 bases (i.e., 25% of the nucleotides differ). Thus, a wrong address would have 6 mismatches in just 24 bases and, therefore, would not be captured at the wrong address, especially under 75-80°C hybridization conditions. In addition, while a particular smaller 12-mer sequence may be found within a 24-mer sequence elsewhere on the grid, an addressable array-specific portion will not hybridize to the 12-mer sequence at temperatures above 50°C.

The starting surfaces will contain free amino groups, a non-cleavable amide linkage will connect the C-terminus of PNA to the support, and orthogonal side-chain deprotection must be carried out upon completion of segment condensation assembly in a way that PNA chains are retained at their addresses. A simple masking device has been designed that contains 200µm spaces and 200µm barriers, to allow each of 5 tetramers to couple to the solid support in distinct rows (Figure 20A). After addition of the first set of tetramers, the masking device is rotated 90°, and a second set of 5 tetramers are added (Figure 20B). This can be compared to putting icing on a cake as rows, followed by icing as columns. The intersections between the rows and columns will contain more icing, likewise, each intersection will contain an octamer of unique sequence. Repeating this procedure for a total of 6 cycles generates 25 squares containing unique 24-mers, and the

remaining squares containing common 12-mers (Figures 20C and 21A-G). The silicon or glass surface will contain 10 $\mu$ m ridges to assure a tight seal, and chambers will be filled under vacuum. A circular manifold (Figure 26) will allow for circular permutation of the six tetramers prior to delivery into the five rows (or columns). This design generates  
5 unique 24-mers which always differ from each other by at least 3 tetramers, even though some sequences contain the same 3 tetramers in a contiguous sequence. This masking device is conceptually similar to the masking technique disclosed in Southern, et al., *Genomics*, 13:1008-1017 (1992) and Maskos, et al., *Nucleic Acids Res.*, 21:2267-2268 (1993), which are hereby incorporated by reference, with the exception that the array is  
10 built with tetramers as opposed to monomers.

Alternatively, the production of the incomplete 12-mer sequences can be eliminated if a mask which isolates each location is used. In the first step (as shown in Figure 19D), PNA tetramers 1, 2, 3, 4, and 5 are linked to the surface in each of the five columns respectively. The multi-chamber device is then rotated 90°. Tetramers 6, 5, 4, 3,  
15 and 2 are added in adjacent rows, as shown in Figure 19E. The process is repeated a total of three times to synthesize 24-mer PNA oligomers. Each completed 24-mer within a given row and column represents a unique PNA sequence, hence achieving the desired addressable array. In addition, each 24-mer will be separated from adjacent oligomers by a 200 $\mu$ m region free of PNA oligomers.

20 A silicon or glass surface will be photochemically etched to produce a crosshatched grid of 10 $\mu$ m raised ridges in a checkerboard pattern (see Figure 20). Alternate squares (200 $\mu$ m x 200 $\mu$ m) will be activated, allowing for the attachment of C<sub>18</sub> alkyl spacers and PEG hydrophilic linkers (MW 400-4,000), such that each square is separated by at least one blank square and two ridges on all sides.

25 An example of a universal array using PNA tetramers can be formed by adding 36 different tetramers to either 36 columns or rows at the same time. The simplest way to add *any* tetramer to *any* row is to have all 36 tetramer solutions attached by tubings to minivalves to a circular manifold which has only one opening. The other side of the circular manifold can be attached to any of 36 minivalves which go to individual rows (or  
30 columns). So by rotating the manifold and minivalves to the chambers (rows), one can pump any tetramer into any row, one at a time. This can be either a mechanical device requiring physical rotation or, alternatively, can be accomplished by using electronic microvalves along a series of import (tetramers) and export (rows) channels. This process can occur quite rapidly (5 seconds, including rinsing out the manifold for its next use), so  
35 that it would take about  $36 \times 5 = 180$  sec. to add all 36 rows.

A potentially more rapid way of filling the rows or columns would be to fill all of them simultaneously. This is illustrated in Figure 20 for a 5 x 5 array. The silicon or glass surface will contain 10 $\mu$ m ridges to assure a tight seal, and chambers will be filled using the vacuum technique described above. A circular manifold will allow for circular  
40 permutation of the six tetramers prior to delivery into the five rows (or columns). In

Figure 20, the first step is 5, 4, 3, 2, 1. When rotating the multi-chamber device, one could continue to add in either numerical, or reverse numerical order. In the example, a numerical order of 2, 3, 4, 5, 6 for the second step is used. In the third step, the circular permutation (reverse) gives 1, 6, 5, 4, 3. Fourth step (forward) 4, 5, 6, 1, 2. Fifth step (reverse) 4, 3, 2, 1, 6. Sixth step (forward) 5, 6, 1, 2, 3. This can be expanded to 36 tetramers into 36 rows (or columns). This approach limits the potential variations in making the address for the array from  $36^6 = 2,176,782,336$  in every position to  $36^6 = 2,176,782,336$  in one position, with the other 1,295 positions now defined by the first address. This is still a vast excess of the number of different addresses needed.

10 Furthermore, each address will still differ from every other address by at least 6 nucleotides.

Note that all of these arrays can be manufactured in groups, just as several silicon chips can be produced on the same wafer. This is especially true of the tetramer concept, because this requires adding the same tetramer in a given row or column. Thus, one row could cover a line of ten arrays, so that a  $10 \times 10$  grid = 100 arrays could be manufactured at one time.

Alternatively, the process described with reference to Figure 20 can be carried out with one less cycle to make a 20 mer oligonucleotide. The capture oligonucleotide should be sufficiently long to capture its complementary addressable array-specific portion under the selected hybridization conditions.

Figures 21A-G show a schematic cross-sectional view of the synthesis of an addressable array (legend). Figure 21A shows attachment of a flexible spacer (linker) to surface of array. Figure 21B shows the synthesis of the first rows of oligonucleotide tetramers. Only the first row, containing tetramer 1, is visible. A multi-chamber device is placed so that additional rows, each containing a different tetramer, are behind the first row. Figure 21C shows the synthesis of the first columns of oligonucleotide tetramers. The multi-chamber device or surface has been rotated  $90^\circ$ . Tetramers 9, 18, 7, and 12 were added in adjacent chambers. Figure 21D shows the second round synthesis of the oligonucleotide rows. The first row contains tetramer 2. Figure 21E shows the second round of synthesis of oligonucleotides. Tetramers 34, 11, 14, and 23 are added in adjacent chambers during the second round. Figure 21F shows the third round synthesis of PNA rows. The first row contains tetramer 3. Figure 21G shows the structure of the array after third round synthesis of columns, adding tetramers 16, 7, 20, 29. Note that all 24-mer oligonucleotides within a given row or column are unique, hence achieving the desired addressable array. Since each 24-mer differs from its neighbor by three tetramers, and tetramers differ from each other by at least 2 bases, then each 24-mer differs from the next by at least 6 bases. Each mismatch significantly lowers  $T_m$ , and the presence of 6 mismatches in just 24 bases would make cross hybridization unlikely even at  $35^\circ\text{C}$ . Note that the smaller 12-mer sequences are identical with one another, but are not at all common with the 24-mer sequences. Even though the particular 12-mer sequence may be

found within a 24-mer elsewhere on the grid, for example 17-1-2-3-28-5, an oligonucleotide will not hybridize to the 12-mer at temperatures above 50°C.

Figures 22A-C present a design for a masking device 2 capable of constructing an array grid G as described in Figures 19-21. Figure 22A is a top view of the arrangement of device 2 and array grid G, while side views Figures 22B-22C are, respectively, taken along line 22B-22B and line 22C-22C of Figure 22A. The masking device contains 200µm spaces and 200µm barriers, to allow each of five tetramers to be coupled to the solid support in distinct rows. After addition of the first set of tetramers, the masking device is rotated 90°, and a second set of 5 tetramers are added. This can be compared to putting icing on a cake as rows, followed by icing as columns. The intersections between the rows and columns will contain more icing, likewise, each intersection will contain an octamer of unique sequence. Repeating this procedure for a total of 6 cycles generates 25 spatially separated squares containing unique 24-mers, and the remaining squares containing common 12-mers. The silicon or glass surface will contain 10µm ridges R to assure a tight seal, and chambers 4 will be filled by opening valves 8 to a vacuum line 12 to create negative pressure in the chamber. The multi-chamber device is pressed onto the membrane or activated solid surface, forming tight seals. The barriers may be coated with rubber or another material to avoid cross contamination from one chamber to the next. One must also make sure the membrane or solid support surface is properly wetted by the solvents. After closing valves 8 to vacuum line 12, one proceeds by activating the surface, deprotecting, and adding a tetramer to a chamber 4 through lines 10 by opening valves 6. The chamber is unclamped, the membrane is rotated 90°, and resealed. A second round of tetramers are added by the above-described vacuum and tetramer application steps. A valve block assembly (Fig. 25A-C) will route each tetramer to the appropriate row. Alternatively, a cylindrical manifold (Figures 26A-D) will allow circular permutation of the six tetramers prior to delivery into the five rows (or columns). This design generates unique 24-mers which always differ from each other by at least 3 tetramers, even though some sequences contain the same 3 tetramers in a contiguous sequence.

Figures 23A-C represent a perspective view of the array construction process described in Figure 19 (Figures 19D-19E). In the first step, as shown in Figure 23A, PNA tetramers 1, 2, 3, 4, and 5 are linked to the surface in each of the five columns, respectively. Each of the 5 locations in the columns are isolated, and there is a 200µm gap between them where no oligonucleotides are coupled. The multi-chamber device is then rotated 90°, as shown in Figure 23B. Tetramers 6, 5, 4, 3, and 2 are added in adjacent rows. Each of the 5 locations in the rows are isolated, and there is a 200µm gap between them where no oligonucleotides are coupled. Each completed 24-mer, as shown in Figure 23C, within a given row and column represents a unique PNA sequence. Unlike the design presented in Figs. 19-22, this array design will not contain the half-size 12-mers between each complete 24-mer, because a mask with isolated locations will be used.

Figures 24A-C present a design for a masking device 2 capable of constructing an array grid G as described in Figure 23. Figure 24A is a top view of the arrangement of device 2 and array grid G, while side views Figure 24B and 24C are, respectively, taken along line 24B-24B and line 24C-24C of Figure 24A. The masking device contains

5 200 $\mu$ m spaces and 200 $\mu$ m barriers, to allow each of five tetramers to be coupled to the solid support in distinct locations on the array grid G. After addition of the first set of tetramers, the masking device or surface is rotated 90°, and a second set of 5 tetramers are added. Repeating this procedure for a total of 6 cycles generates 25 spatially separated squares containing unique 24-mers, and the remaining squares containing common 12-

10 mers. The silicon or glass surface will contain 10 $\mu$ m ridges R to assure a tight seal, and chambers 4 will be filled by a procedure initiated by using a vacuum to create negative pressure in the chamber 2. This vacuum is created by opening valves 8 to vacuum line 12. The multi-chamber device is pressed onto the membrane or activated solid surface, forming tight seals. The barriers may be coated with rubber or another material to avoid

15 cross contamination from one chamber to the next. One must also make sure the membrane or solid support surface is properly wetted by the solvents. After closing valves 8 to vacuum line 12, one proceeds by activating the surface, deprotecting, and adding a tetramer to chamber 4 through lines 10 by opening valves 6. The chamber is unclamped, the membrane is rotated 90°, and resealed. A second round of tetramers are added by

20 the above-described vacuum and tetramer application steps. A valve block assembly (Fig. 25A-C) will route each tetramer to the appropriate row. Alternatively, a cylindrical manifold (Fig. 26A-D) will allow circular permutation of the six tetramers prior to delivery into the five rows (or columns). This design generates unique 24-mers which are separated from each other by a region free of any oligonucleotides.

25 Figures 25A-C show a valve block assembly 14 which connects six input ports 10 to five output ports 16 via a common chamber 18. Each of the 6 input ports 10 and 5 output ports 16 contains a valve 6 and a valve 20, respectively, which control the flow of fluids. The 6 input tubes 10 contain different solutions, and the valve block assembly 14 is capable of routing any one of the input fluids to one of the 5 output ports 16 at a time.

30 This is accomplished by opening the valve 6 of one of the input ports 10 and one of the valves 20 of the output ports 16 simultaneously and allowing fluid to fill the chamber 18 and exit via the output port 16 connected to the open valve 20. The valve block assembly 14 is connected to a source of solvent 22 and a source of vacuum 12 via valves 24 and 8, respectively, in order to allow cleaning of the central chamber 18 in between fluid

35 transfers. The solvent fills the chamber 18, and the vacuum is used to remove all fluid from the chamber. This prepares the chamber 18 for the next fluid transfer step and prevents cross-contamination of the fluids.

Figures 26A-D depict a cylindrical manifold assembly 114 which transfers 6 different tubes of input fluids to 5 different output tubes. The manifold itself contains two

40 separate halves 114A and 114B which are joined by a common, central spoke 134 around

which both halves can independently rotate. The bottom portion 114B is a cylindrical block with 6 channels 130 drilled through it (see Figure 26C, which is a bottom view of Figure 26B taken along line 26C-26C of Figure 26B). Each of the 6 channels 130 are attached to 6 different input tubes 110. The input tubes 110 contain valves 106 which  
5 connect the input channels 130 to either reagents, solvent, or a vacuum via lines 138 having valves 136 leading to vacuum line 112 having valve 108 and solvent line 122 having valve 124. This allows different fluids to enter the channels 130 and 132 of the manifold and allows clearing of the channels 130 and 132 of excess fluid between fluid transfers. The upper portion of the manifold (see Figure 26A, which is a top view of  
10 Figure 26B taken along line 26A-26A of Figure 26B) is also a cylindrical block with 5 channels 132 drilled through it. The 5 channels 132 are each connected to a different output tube 116. The two halves of manifold 114A and 114B can be independently rotated so that different input channels 130 will line up with different output channels 132. This allows the 6 tubes of input fluids to be transferred to the 5 output tubes  
15 simultaneously. The bottom half of the manifold 114B can be rotated 60 degrees in order to align each input port 110 with the next output port 116. In this way, each input port 110 can be aligned with any of the output ports 116. The circular manifold of Figures 26A-D differs from the valve block assembly of Figures 26A-C in that the former can simultaneously transfer five of the six input fluids to the five output ports, because it has 5  
20 channels connecting input ports to the output ports. This concept could be easily expanded to deliver 36 tetramers simultaneously to 36 locations.

The present invention contains a number of advantages over prior art systems.

The solid support containing DNA arrays, in accordance with the present invention, detects sequences by hybridization of ligated product sequences to specific locations on  
25 the array so that the position of the signal emanating from captured labels identifies the presence of the sequence. For high throughput detection of specific multiplexed LDR products, addressable array-specific portions guide each LDR product to a designated address on the solid support. While other DNA chip approaches try to distinguish closely related sequences by subtle differences in melting temperatures during solution-to-surface  
30 hybridization, the present invention achieves the required specificity prior to hybridization in solution-based LDR reactions. Thus, the present invention allows for the design of arrays of capture oligonucleotides with sequences which are very different from each other. Each LDR product will have a unique addressable array-specific portion, which is captured selectively by a capture oligonucleotide at a specific address on the solid support.  
35 When the complementary capture oligonucleotides on the solid support are either modified DNA or PNA, LDR products can be captured at higher temperatures. This provides the added advantages of shorter hybridization times and reduced non-specific binding. As a result, there is improved signal-to-noise ratios.

Another advantage of the present invention is that PCR/LDR allows detection of closely-clustered mutations, single-base changes, and short repeats and deletions. These are not amenable to detection by allele-specific PCR or hybridization.

In accordance with the present invention, false hybridization signals from DNA synthesis errors are avoided. Addresses can be designed so there are very large differences in hybridization  $T_m$  values to incorrect address. In contrast, the direct hybridization approaches depend on subtle differences. The present invention also eliminates problems of false data interpretation with gel electrophoresis or capillary electrophoresis resulting from either DNA synthesis errors, band broadening, or false band migration.

The use of a capture oligonucleotide to detect the presence of ligation products, eliminates the need to detect single-base differences in oligonucleotides using differential hybridization. Other existing methods in the prior art relying on allele-specific PCR, differential hybridization, or sequencing-by-hybridization methods must have hybridization conditions optimized individually for each new sequence being analyzed. When attempting to detect multiple mutations simultaneously, it becomes difficult or impossible to optimize hybridization conditions. In contrast, the present invention is a general method for high specificity detection of correct signal, independent of the target sequence, and under uniform hybridization conditions. The present invention yields a flexible method for discriminating between different oligonucleotide sequences with significantly greater fidelity than by any methods currently available within the prior art.

The array of the present invention will be universal, making it useful for detection of cancer mutations, inherited (germline) mutations, and infectious diseases. Further benefit is obtained from being able to reuse the array, lowering the cost per sample.

The present invention also affords great flexibility in the synthesis of oligonucleotides and their attachment to solid supports. Oligonucleotides can be synthesized off of the solid support and then attached to unique surfaces on the support. Segments of multimers of oligonucleotides, which do not require intermediate backbone protection (e.g., PNA), can be synthesized and linked onto to the solid support. Added benefit is achieved by being able to integrate these synthetic approaches with design of the capture oligonucleotide addresses. Such production of solid supports is amenable to automated manufacture, obviating the need for human intervention and resulting contamination concerns.

An important advantage of the array of the present invention is the ability to reuse it with the previously attached capture oligonucleotides. In order to prepare the solid support for such reuse, the captured oligonucleotides must be removed without removing the linking components connecting the captured oligonucleotides to the solid support. A variety of procedures can be used to achieve this objective. For example, the solid support can be treated in distilled water at 95-100°C, subjected to 0.01 N NaOH at room temperature, contacted with 50% dimethylformamide at 90-95°C, or treated with 50% formamide at 90-95°C. Generally, this procedure can be used to remove captured



oligonucleotides in about 5 minutes. These conditions are suitable for disrupting DNA-DNA hybridizations; DNA-PNA hybridizations require other disrupting conditions.

The present invention is illustrated, but not limited, by the following examples.

5

## EXAMPLES

### **Example 1 - Immobilization of capture oligonucleotides to solid supports**

The solid support for immobilization was glass, in particular microscope slides.

10 The immobilization to glass (e.g., microscope slides), or other supports such as silicon (e.g., chips), membranes (e.g., nylon membranes), beads (e.g., paramagnetic or agarose beads), or plastics supports (e.g., polyethylene sheets) of capture oligonucleotides in spatially addressable arrays is comprised of 5 steps:

15

#### A. Silanization of support

The silanization reagent was 3-aminopropyl triethoxysilane ("APTS").

Alternatively, 3-glycidoxypropyltrimethoxysilane (K.L. Beattie, et al., "Advances in Genosensor Research," Clin. Chem., 41:700-706 (1995); U. Maskos, et al.,  
20 "Oligonucleotide Hybridizations on Glass Supports: a Novel Linker for Oligonucleotide Synthesis and Hybridization Properties of Oligonucleotides Synthesized *in situ*," Nucleic Acids Res., 20:1679-1684 (1992); C.F. Mandenius, et al., "Coupling of Biomolecules to Silicon Surfaces for Use in Ellipsometry and Other Related Techniques," Methods Enzymol., pp. 388-394 (1988), which are hereby incorporated by reference) or  
25 3-(trimethoxysilyl)propyl methacrylate (M. Glad, et al., "Use of Silane Monomers for Molecular Imprinting and Enzyme Entrapment in Polysiloxane-coated Porous Silica," J. Chromatogr. 347:11-23 (1985); E. Hedborg, et al., "Some Studies of Molecularly-imprinted Polymer Membranes in Combination with Field-effect Devices," Sensors and Actuators A 37-38:796-799 (1993); and M. Kempe, et al., "An Approach Towards Surface  
30 Imprinting Using the Enzyme Ribonuclease A," J. Mol. Recogn. 8:35-39 (1995), which are hereby incorporated by reference) can be used as an initial silanization reagent. Prior to silanization, the support was cleansed and the surface of the support was rendered hydrophobic. Glass slides (Fisher Scientific, Extra thick microslides, frosted cat.# 12-550-11) were incubated in conc. aq. NH<sub>4</sub>OH-H<sub>2</sub>O<sub>2</sub>-H<sub>2</sub>O (1:1:5, v/v/v) at 80°C for 5  
35 min and rinsed in distilled water. The support was then washed with distilled water, ethanol and acetone as described in the literature (C.F. Mandenius, et al., "Coupling of Biomolecules to Silicon Surfaces for Use in Ellipsometry and Other Related Techniques," Methods Enzymol., pp. 388-394 (1988); Graham, et al., "Gene Probe Assays on a Fibre-Optic Evanescent Wave Biosensor," Biosensors & Bioelectronics, 7: 487-493 (1992);  
40 Jönsson, et al., "Adsorption Behavior of Fibronectin on Well Characterized Silica Surfaces," J. Colloid Interface Sci., 90:148-163 (1982), which are hereby incorporated by

reference). The support was silanized overnight at room temperature in a solution of 2 % (v/v) 3-aminopropyl triethoxysilane (Sigma, St. Louis, MO) in dry acetone (99.7 %) (modified after Z. Guo, et. al., "Direct Fluorescence Analysis of Genetic Polymorphisms by Hybridization with Oligonucleotide Arrays on Glass Supports," Nucl. Acids Res. 22:5456-65 (1994), which is hereby incorporated by reference). The support was then thoroughly washed in dry acetone and dried at 80°C in a vacuum desiccator.

B. *Derivatization of silanized solid support with functional groups (e.g., carboxyl or amino groups)*

10

When the silanization reagent was APTS, the desired amino functionality was introduced directly. Other functional groups can be introduced, either by choosing an appropriate silanization reagent primer that already contains the functional group (e.g., 3-(trimethoxysilyl)propyl methacrylate to functionalize the surface with a polymerizable acrylate, (M. Glad, et al., "Use of Silane Monomers Imprinting and Enzyme Entrapment in Polysiloxane-coated Porous Silica," J. Chromatogr. 347:11-23 (1985); E. Hedborg, et al., "Some Studies of Molecularly-imprinted Polymer Membranes in Combination with Field-effect Devices," Sensors and Actuators A 37-38:796-799 (1993); and M. Kempe, et al., "An Approach Towards Surface Imprinting Using the Enzyme Ribonuclease A," J. Mol. Recogn. 8:35-39 (1995), which are hereby incorporated by reference), or by reacting the amino-functionalized surface with a reagent that contains the desired functional group (e.g., after localized light-directed photodeprotection of protected amino groups used in photolithography, (Fodor, et al., "Light-Directed, Spatially Addressable Parallel Chemical Synthesis," Science, 251:767-773 (1991); Fodor, et al., "Multiplexed Biochemical Assays with Biological Chips," Nature, 364:555-556 (1993), which are hereby incorporated by reference)).

C. *Activation of functional groups*

30 The functional group on the solid support was an amino group. Using a prefabricated mask with a 5 x 5 array of dots that have a diameter of 1 mm, and that are 3.25 mm apart, small amounts (typically 0.2 to 1.0 µl) of a solution containing 70 mg/ml disuccinimidyl adipate ester (Hill, et al., "Disuccinimidyl Esters as Bifunctional Crosslinking Reagents for Proteins," FEBS Lett. 102:282-286 (1979); Horton, et al., "Covalent Immobilization of Proteins by Techniques which Permit Subsequent Release," Methods Enzymol., pp. 130-141 (1987), which are hereby incorporated by reference) in anhydrous dimethylformamide ("DMF"); Aldrich, Milwaukee, WI), amended with 1-2% triethylamine (to scavenge the acid that is generated), were manually applied to the solid support using a Gilson P-10 pipette. After application, the reaction was allowed to proceed for 30 min at room temperature in a hood, after which another loading of

40

disuccinimidyl adipate ester was applied. After a total reaction time of 1 hour, the support was washed with anhydrous DMF and dried at room temperature in a vacuum desiccator.

In case the functional group is a carboxyl group, the solid support can be reacted with 1-ethyl-3-(3-dimethylaminopropyl) carbodiimide hydrochloride ("EDC"). Frank, et al., "Simultaneous Multiple Peptide Synthesis Under Continuous Flow Conditions on Cellulose Paper Discs as Segmental Solid Support," *Tetrahedron*, 44:6031-6040 (1988), which is hereby incorporated by reference. Prior to this reaction, the surface of the solid support was protonated by a brief treatment with 0.1 N HCl. Using the above described prefabricated mask, small amounts (0.2 to 1.0  $\mu$ l) of a fresh solution containing 1 M EDC (Sigma, St. Louis, MO), 1 mM of 5' amino-modified oligonucleotide and 20 mM  $\text{KH}_2\text{PO}_4$ , pH = 8.3, was manually applied to the solid support. The reaction was allowed to proceed for 1 hour, after which the support was washed with distilled water and dried at room temperature in a vacuum desiccator.

15 D. *Coupling of amino-functionalized capture oligonucleotides to the preactivated solid support*

For supports other than EDC-activated solid supports, small amounts (0.2 to 1.0  $\mu$ l) of 1 nmol/ $\mu$ l 5' amino-modified oligonucleotides (i.e. the sequences in Table 2) in 20 mM  $\text{KH}_2\text{PO}_4$ , pH 8.3, were manually applied to the activated support, again using the prefabricated mask described above. The reaction was allowed to proceed for 1 hour at room temperature.

25 E. *Quenching of remaining reactive groups on the solid support*

In order to prevent the reaction products from being nonspecifically captured on the solid support in a capture probe-independent way, it may be necessary to quench any remaining reactive groups on the surface of the solid support after capture of the complementary oligonucleotide probes. Hereto, the support was incubated for 5 min at 30 room temperature in 0.1 N sodium hydroxide. Alternatively, quenching can be performed in 0.2 M lysine, pH = 9.0. After quenching, the support was washed with 0.1 N sodium phosphate buffer, pH 7.2, to neutralize the surface of the support. After a final wash in distilled water the support was dried and stored at room temperature in a vacuum desiccator.

35 **Example 2 - Design of the Assay System**

A semi-automated custom-designed assay system was made for testing hybridizations and subsequent washings of captured oligonucleotide probe-capture 40 oligonucleotide hybrids in a high-throughput format using the GeneAmp *In Situ* PCR System 1000<sup>TM</sup> (Perkin Elmer, Applied Biosystems Division, Foster City, CA) (G.J.

Nuovo, PCR *in situ* Hybridization, New York: Raven Press (2nd ed. 1994), which is hereby incorporated by reference). A general flowchart of the system is shown in Fig. 27. The system consists of a flow-through hybridization chamber which is connected via a sample loading device and a multiple port system to a battery of liquid reservoirs, and to a waste reservoir. The fluid delivery is controlled by a pump. The pump was placed at the end of the assembly line and operated under conditions to maintain a light vacuum to prevent leakage and contamination of the system. Since the hybridization chamber and the liquid reservoirs were designed to fit precisely within the GeneAmp *In Situ* PCR System 1000™, temperatures can be accurately controlled and maintained during the hybridization and washing steps of the assay.

The individual parts of the system are described in detail in the following section:

#### A. *Hybridization chamber*

The hybridization chamber is an *in situ* PCR reagent containment system that has been modified to accommodate flow-through characteristics. The containment system is comprised of a glass microscope slide (76 x 25 x 1.2 ± 0.02 mm) and a silicone rubber diaphragm, which has been clamped to the slide by a thin stainless steel clip. The inside oval rim of the metal clip compresses the edges of the silicon disc against the slide with enough force to create a water and gas-tight seal ensuring the containment of hybridization probes and washing liquids. The volume of the containment is approximately 50 µl. The array of immobilized capture oligonucleotides is contained in the central area of the slide (approximately 13 mm x 15 mm) which is covered by the silicon disc. The assembly of the different parts is facilitated by an assembly tool which is provided by the manufacturer of the *in situ* PCR system. Once assembled, an inlet and outlet of the hybridization chamber is created by insertion of two 25G3/4 needles with 12" tubing and multiple sample luer adapter (Becton Dickinson, Rutherford, NJ). The needles are inserted in a diagonal manner to assure an up-and-across flow pattern during washing of the probe-target hybrids.

#### B. *Liquid reservoirs*

Reservoirs containing different washing solutions were custom-designed to fit into the vertical slots of the thermal block of the GeneAmp *In Situ* PCR System 1000™. Each reservoir consists of two glass microscope chamber slides (25 x 75 x 1 mm) containing prefabricated silicone gaskets (Nunc, Inc., Napierville, IL), which were glued to each other using silicone sealant (Dow Corning, Midland, MI). An outlet was created by insertion of a 21G 3/4" needle with 12" long tubing and multiple sample luer adapter (Becton Dickinson, Rutherford, NJ) through the silicone gasket. A second 21G 3/4" needle without tubing (Becton Dickinson, Franklin Lakes, NJ) was inserted through the silicone

gasket to create an air inlet. The liquid reservoirs are leak-free and fit precisely within the slots of the thermal block, where they are clamped against the metal fins to assure good heat transfer to the contained liquid. The volume of each reservoir is approximately 2 ml.

5 C. *Multi port system and sample loading device*

Liquid reservoirs, sample loading device and hybridization chamber are connected through a multiple port system that enables a manually controlled unidirectional flow of liquids. The system consists of a series of 3-way nylon stopcocks with luer adapters  
10 (Kontes Scientific Glassware/Instruments, Vineland, NJ) that are connected to each other through male-female connections. The female luer adapters from the liquid reservoirs are connected to the multi port female luer adapters via a male-to-male luer adapter coupler (Biorad, Richmond, CA). The sample loading device is placed in between the ports connected to the liquid reservoirs and the port connected to the hybridization chamber. It  
15 consists of a 1 ml syringe (Becton Dickinson, Franklin Lakes, NJ) that is directly connected via a luer adapter to the multi port system. The flow of liquids can be controlled manually by turning the handles on the stopcocks in the desired direction.

20 D. *Waste reservoir*

The outlet tubing from the hybridization chamber is connected to a waste reservoir which consists of a 20 ml syringe with luer adapter (Becton Dickinson, Franklin Lakes, NJ) in which the plunger has been secured at a fixed position. A connection to the pump is established by insertion of a 21G 3/4" needle with 12" long tubing and multiple sample  
25 luer adapter through the rubber gasket of the plunger. When the pump is activated, a slight vacuum is built up in the syringe which drives the flow of liquids from the liquid reservoirs through the hybridization chamber to the waste reservoir.

30 E. *Pump*

A peristaltic pump P-1 (Pharmacia, Piscataway, NJ) was used to control the flow of liquids through the system. It was placed at the end of the assembly line in order to maintain a slight vacuum within the system. The inlet tubing of the pump was connected to the outlet tubing of the waste reservoir via a 3-way nylon stopcock. By this  
35 construction release of the vacuum within the waste reservoir is established enabling its draining by gravity.

**Example 3 - Hybridization and washing conditions**

In order to assess the capture specificity of different capture oligonucleotides, hybridization experiments were carried out using two capture oligonucleotide probes that had 3 out of 6 tetramers (i.e., 12 out of 24 nucleotides) in common. This example represents the most difficult case to distinguish between different capture oligonucleotides. In general, other capture oligonucleotides would be selected that would have fewer tetramers in common to separate different amplification products on an addressable array.

Typically, 10 pmol of each of the oligonucleotides comp 12 and comp 14 (see Table 3) were 5' end labeled in a volume of 20  $\mu$ l containing 10 units of T4 polynucleotide kinase (New England Biolabs, Beverly, MA), 2.22 MBq (60  $\mu$ Ci) [ $\gamma$ -<sup>32</sup>P] ATP, 50 mM Tris-HCl, pH 8, 10 mM MgCl<sub>2</sub>, 1 mM EDTA, and 10 mM dithiothreitol, according to a slightly modified standard procedure described in the literature. Unincorporated radioactive nucleotides were removed by filtration over a column containing superfine DNA grade Sephadex G-25 (Pharmacia, Piscataway, NJ). The Sephadex was preswollen overnight at 4 °C in 10 mM ammonium acetate. The labeled oligonucleotide probes were dried in vacuum and dissolved in hybridization solution (0.5 M Na<sub>2</sub>HPO<sub>4</sub> [pH 7.2], 1% crystalline grade BSA, 1 mM EDTA, 7% SDS). The specific activity of the labeled oligonucleotide probes comp 12 and comp 14 was 2.86 x 10<sup>6</sup> cpm/pmol and 2.43 x 10<sup>6</sup> cpm/pmol, respectively.

**Table 3. Oligonucleotides used (5' to 3')**

12	Aminolink- spacer 18- ATC GGG TAG GTA ACC TTG CGT GCG
14	Aminolink- spacer 18- GGT AGG TAA CCT ACC TCA GCT GCG
comp 12	CGC ACG CAA GGT TAC CTA CCC GAT
comp 14	CGC AGC TGA GGT AGG TTA CCT ACC

25

Four hundred picomoles of amino-linked capture oligonucleotides 12 and 14 (see Table 3) were deposited and reacted both on carboxyl derivatized and amino derivatized glass microscope slides as described in the previous section. The capture oligonucleotides were immobilized in a 2 x 2 matrix array, in such a way that hybridization with the complementary oligonucleotide probe comp 12 would result in a positive signal for the top-left and bottom-right diagonal positions, while hybridization with the complementary oligonucleotide probe comp 14 would result in a positive signal for the bottom-left and top-right diagonal positions.

Radiolabeled oligonucleotide probes comp 12 and comp 14 (see Table 3) were dissolved in hybridization solution at a concentration of 2.5 pmol/100  $\mu$ l and 4.1 pmol/100  $\mu$ l, respectively. The hybridization solutions were amended with 5  $\mu$ l of a 2%

35

bromophenol blue marker to facilitate the visual monitoring of the probes during their transport through the assay system. One hundred microliters of radiolabeled probe was then injected and pumped into the hybridization chamber. Hybridizations were performed for 15 min at 70°C.

- 5 After hybridization, the hybridization chamber was sequentially washed with 2 x 2 ml of low stringency wash buffer (2 x SSC buffer contains 300 mM sodium chloride and 30 mM sodium citrate), 0.1% sodium dodecylsulfate ("SDS") and 2 x 2 ml of high stringency wash buffer (0.2 x SSC, 0.1% SDS) at 70 °C. (1x SSC buffer contains 150 mM sodium chloride and 15 mM sodium citrate).

10

#### Example 4 - Detection of captured oligonucleotide probes

- After washing the capture oligonucleotide-oligonucleotide probe hybrids, silicon discs, needles and metal cover clips were removed from the glass microscope slides, and remaining liquid was absorbed using Kimwipes (Kimberly-Clark, Roswell, GA). The captured oligonucleotide probes were visualized and quantified using a phosphorimager (Molecular Dynamics, Sunnyvale, CA). After 21 hours of exposure of the glass microscope slide to a phosphorimager screen, data were collected for the different solid supports that were tested. The images that were obtained are shown in Fig. 28.

- 20 Quantitative data are shown in Tables 4A and 4B.

Under the conditions that were used, the signals and cross-reactivity data that were obtained for the NH<sub>2</sub>-functionalized slides were better than those obtained for the COOH-functionalized slides.

25 **Table 4A. Quantification of captured oligonucleotide probe 12**

Functional group on slide	Probe	Oligonucleotide probe at capture oligonucleotide 12		Oligonucleotide probe at capture oligonucleotide 14		Average cross reactivity
		(pic)*	(amol)	(pic)*	(amol)	
-COOH	12	105,333	9.0			0.37
-COOH	12	55,957	4.8			
-COOH	12			36,534	3.1	
-COOH	12			23,707	2.0	
-NH <sub>2</sub>	12	353,569	30			0.015
-NH <sub>2</sub>	12	10,421,092	889			
-NH <sub>2</sub>	12			64,999	5.5	
-NH <sub>2</sub>	12			95,414	8.1	

\* pic = relative phosphorimager counts

Table 4B. Quantification of captured oligonucleotide probe 14

Functional group	Probe	Oligonucleotide probe at capture oligonucleotide 12		Oligonucleotide probe at capture oligonucleotide 14		Average cross reactivity
		(pic)*	(amol)	(pic)*	(amol)	
-COOH	14			35,610	4.0	0.19
-COOH	14			43,362	4.9	
-COOH	14	5,587	0.6			
-COOH	14	9,379	1.1			
-NH <sub>2</sub>	14			245,973	28	0.049
-NH <sub>2</sub>	14			115,529	13	
-NH <sub>2</sub>	14	9,775	1.1			
-NH <sub>2</sub>	14	8,065	0.9			

\* pic = relative phosphorimager counts

5

#### Example 5 - Optimizing immobilization parameters of capture oligonucleotides

Polymer was deposited on slides using a literature procedure. Barnard, et al., "A Fibre-optic Sensor With Discrete Sensing Sites," *Nature* 353:338-40 (1991); Bonk, et al., "Fabrication of Patterned Sensor Arrays With Aryl Azides on a Polymer-coated Imaging Optical Fiber Bundle," *Anal. Chem.* 66:3319-20 (1994); Smith, et al., "Poly-N-acrylylpyrrolidone -- A New Resin in Peptide Chemistry," *Int. J. Peptide Protein Res.* 13:109-12 (1979), which are hereby incorporated by reference.

Four hundred picomoles of amino-linked capture oligonucleotides 12 and 14 (see Table 3) were deposited and reacted in a 2 x 2 pattern to a glass microscope slide that contained 4 identical photo-deposited polymer spots. The oligonucleotides were spotted in such a way that hybridization with the complementary oligonucleotide probe comp 12 would result in a positive signal for the top and bottom positions, while hybridization with the complementary oligonucleotide probe comp 14 would result in a positive signal for the left and right positions.

Radiolabeled oligonucleotide probe comp 12 (see Table 3) was dissolved in hybridization solution at a concentration of 2.4 pmol/100  $\mu$ l. Bromophenol blue marker (5  $\mu$ l of a 2% solution) was added to the hybridization solution to facilitate the monitoring of the probe during its transport through the system.

One hundred microliters of radiolabeled probe comp 12 was pumped into the hybridization chamber. Hybridization was performed for 15 min at 70 °C. After hybridization, the hybridization chamber was sequentially washed with 3 x 1 ml of low

25



stringency wash buffer (2 x SSC, 0.1% SDS) and 3 x 1 ml of high stringency wash buffer (0.2 x SSC, 0.1% SDS) at 70 °C.

After 24 hours of exposure of the glass microscope slide to a phosphorimager screen, data were collected for all the different slides that were tested. The images that were obtained are shown in Fig. 29. Quantitative data are shown in Table 5.

**Table 5. Quantification of captured oligonucleotide probes**

Crosslinker	Percentage crosslinker	probe 12 (pic)*	probe 12 (amol)
EGDMA	2	1,055,100	80
		1,390,499	106
HDDMA	2	633,208	48
		286,9371	218
EGDMA	4	4,449,001	338
		2,778,414	211

EGDMA = ethylene glycol dimethacrylate

HDDMA = hexane diol dimethacrylate

\* pic = relative phosphorimager counts

The immobilization chemistry allows for the use of tailor-made specialty polymer matrices that provide the appropriate physical properties that are required for efficient capture of nucleic acid amplification products. The specificity of the immobilized capture oligonucleotides has been relatively good compared to current strategies in which single mismatches, deletions, and insertions are distinguished by differential hybridization (K.L. Beattie, et. al. "Advances in Genosensor Research," *Clin. Chem.* 41:700-06 (1995), which is hereby incorporated by reference). Finally, it has been demonstrated that the assay system of the present invention enables the universal identification of nucleic acid oligomers.

#### **Example 6 - Capture of Addressable Oligonucleotide Probes to Solid Support**

Polymer-coated slides were tested for their capture capacity of addressable oligonucleotide probes following different procedures for immobilization of capture oligonucleotides. After being silanized with 3-(trimethoxysilyl) propyl methacrylate, monomers were then polymerized on the slides. In one case, a polymer layer having COOH functional groups was formed with a polyethylene glycol-containing crosslinker. In the other case, a polyethylene glycol-methacrylate monomer was polymerized onto the slide to form OH functional groups. The slides with the COOH functional groups were activated using the EDC-activation procedure of Example 1.

The slide with OH functional groups was activated overnight at room temperature by incubation in a tightly closed 50 ml plastic disposable tube (Corning Inc., Corning, N.Y.) containing 0.2 M 1,1'-carbonyldiimidazole ("CDI") (Sigma Chemical Co., St. Louis, Mo.) in "low water" acetone (J.T. Baker, Phillipsburg, N.J.). The slide was then washed  
5 with "low water" acetone, and dried in vacuum at room temperature.

Amino-linked capture oligonucleotide 14 was manually spotted on premarked locations on both sides (4 dots per slide). The reactions were performed in a hood, and the amount of oligonucleotide that was spotted was 2 x 0.2  $\mu$ l (0.8 nmol/ $\mu$ l). The total  
10 reaction time was 1 hr. The slides were then quenched for 15 min by the application of few drops of propylamine on each of the premarked dots. After quenching, the slides were incubated for 5 min in 0.1 N sodium phosphate buffer, pH 7.2, washed in double distilled  
20 H<sub>2</sub>O, and dried in vacuum.

The complementary capture oligonucleotides on the slides were hybridized with radioactively labeled oligonucleotide probe comp 14 (Table 3). One hundred microliters  
15 radiolabeled oligonucleotide probe comp 14 (2.8 pmol; 6,440,000 cpm/pmol) were pumped into the hybridization chamber. Hybridization was performed for 15 min at 70° C in 0.5 M Na<sub>2</sub>HPO<sub>4</sub> [pH 7.2], 1% crystalline grade BSA, 1 mM EDTA, 7% SDS. After hybridization, the hybridization chamber was sequentially washed with 2 x 2 ml of low stringency wash buffer (2 x SSC, 0.1% SDS) and 2 x 2 ml of high stringency wash buffer  
20 (0.2 x SSC, 0.1% SDS) at 70°C. (1 SSC buffer contains 150 mM sodium chloride and 15 mM sodium citrate).

After 30 min of exposure of the glass microscope slide to a phosphorimager screen, data were collected for both slides. After 30 minutes of exposure of the glass  
25 microscope slides to a phosphorimager screen data were collected. See Table 6 and Figure 30.

**Table 6. Quantification of capture oligonucleotide probe 14 on OH-functionalized slides**

Functional group on glass slide	Probe	Oligonucleotide probe at capture oligonucleotide 14	
		(pic)*	(fmol)
-OH	14	1,864,879	10.9
-OH	14	1,769,403	10.3

30 \* pic = relative phosphorimager counts

In this test, better results were obtained with the slide coated with the polymer containing OH functional groups than with the slide coated with the polymer containing COOH functional groups.

35 With previously prepared (poly HEMA)-containing polymers that were polymerized with 20% amine-containing monomers and crosslinked with 4 % EGDMA or

HDDMA, it was possible to capture about 275 amol of radioactively labelled ligated product sequence (which could only be visualized after 23 hours of exposure to a phosphorimager screen (Table 5)). Using the polyethylene-methacrylate polymer formulations, it was possible to capture about 10.6 fmoles of ligated product sequence.

- 5 The signal could be detected after 30 min of exposure.

#### Example 7 - Detection of Captured Oligonucleotides Using a Membrane Support

10 In order to assess the capture specificity of different capture oligonucleotides using a membrane support, hybridization experiments were carried out using the capture oligonucleotide probes 12 and 14 (Table 3).

15 Strips of OH-functionalized nylon membrane (Millipore, Bedford, Massachusetts) were soaked overnight in a 0.2 M solution of carbonyldiimidazole in "low water" acetone. The strips were washed in acetone and dried *in vacuo*. Two volumes of 0.2  $\mu$ l (1 mM) capture oligonucleotides 12 and 14 in 20 mM  $K_2HPO_4$ , pH 8.3, (Table 3) were loaded on the membrane using a special blotting device (Immunetics, Cambridge, Massachusetts). Complementary oligonucleotide probes were radioactively labeled as described in Example 3. The oligonucleotide probes were dried *in vacuo* and taken up in 200  $\mu$ l hybridization buffer (0.5 M  $Na_2HPO_4$  [pH 7.2], 1% crystalline grade BSA, 1 mM EDTA, 20 7% SDS). Membranes were prehybridized in 800  $\mu$ l hybridization buffer for 15 min at 60°C in 1.5ml Eppendorf tubes in a Hybaid hybridization oven. The tubes were filled with 500  $\mu$ l of inert carnauba wax (Strahl & Pitsch, Inc., New York, New York) to reduce the total volume of the hybridization compartment. After prehybridization, 200  $\mu$ l of radiolabeled probe was added. The membranes were hybridized for 15 min at 60°C. After hybridization, the membranes were 25 washed at 60°C, twice for 15 min with 1 ml of low stringency wash buffer (2 x SSC, 0.1% SDS), and twice for 15 min with 1 ml of high stringency wash buffer (0.2 x SSC, 0.1% SDS). The captured oligonucleotide probes were quantified using a phosphorimager (Molecular Dynamics, Sunnyvale, CA). After 45 min of exposure to a phosphorimager screen, data were collected. The results are shown in Table 7; where the activities of capture oligonucleotides 12 and 14 are 112 30 pic/amol and 210 pic/amol, respectively.

**Table 7. Quantification of captured oligonucleotides on membranes**

Functional group	Probe	Oligonucleotide probe at capture oligonucleotide 12		Oligonucleotide probe at capture oligonucleotide 14		Average cross reactivity
		(pic)*	(fmol)	(pic)*	(fmol)	
-OH	12	13,388,487	119.5	337,235	3.01	0.025
-OH	12	13,299,298	118.7			
-OH	14	179,345	0.85	1,989,876	9.48	0.071
-OH	14			3,063,387	14.59	

\* pic = relative phosphorimager counts

5

Hybridization temperatures and hybridization times were further explored in a series of similar experiments. The data shown in Table 8 (where the activities of capture oligonucleotides 12 and 14 are 251 pic/amol and 268 pic/amol, respectively) represent the results obtained with the following conditions: 15 min prehybridization at 65°C in 800 µl hybridization buffer; 15 min hybridization at 65°C in 1 ml hybridization buffer; 2 x washings for 5 min at 65°C with 1 ml of low stringency wash buffer; and 2 x washings for 5 min at 65°C with 1 ml of high stringency wash buffer.

10

**Table 8. Quantification of captured oligonucleotides on membranes**

15

Functional group	Probe	Oligonucleotide probe at capture oligonucleotide 12		Oligonucleotide probe at capture oligonucleotide 14		Average cross reactivity
		(pic)*	(fmol)	(pic)*	(fmol)	
-OH	12	41,023,467	163.4	541,483	2.16	0.015
-OH	12	31,868,432	127.0			
-OH	14	294,426	1.10	19,673,325	73.41	0.016
-OH	14			18,302,187	68.29	

\* pic = relative phosphorimager counts

20

The data shown in Table 9 (where the activities of capture oligonucleotides 12 and 14 are 487 pic/amol and 506 pic/amol, respectively) represent the results obtained with the following conditions: 15 min prehybridization at 70°C in 150 µl hybridization buffer; 15 min hybridization at 70°C in 200 µl hybridization buffer; 2 x washings for 5 min at 70°C in 800 µl of low stringency wash buffer; and 2 x washings for 5 min at 70°C in 800 µl of high stringency wash buffer.

**Table 9. Quantification of captured oligonucleotides on membranes**

Functional group	Probe	Oligonucleotide probe at capture oligonucleotide 12		Oligonucleotide probe at capture oligonucleotide 14		Average cross reactivity
		(pic)*	(fmol)	(pic)*	(fmol)	
-OH	12	34,648,385	71.15	1,158,832	2.38	0.027
-OH	12	52,243,549	107.28			
-OH	14	1,441,691	2.85	56,762,990	112.18	0.028
-OH	14			45,769,158	90.45	

\* pic = relative phosphorimager counts

5

The data shown in Table 10 represent the results obtained with the following conditions: 15 min prehybridization at 70°C in 150 µl hybridization buffer; 5 min hybridization at 70°C in 200 µl hybridization buffer; 2 x washings for 5 min at 70°C with 800 µl of low stringency wash buffer; and 2 x washings for 5 min at 70°C with 800 µl of high stringency wash buffer.

10

**Table 10. Quantification of captured oligonucleotides on membranes.**

Functional group	Probe	Oligonucleotide probe at capture oligonucleotide 12		Oligonucleotide probe at capture oligonucleotide 14		Average cross reactivity
		(pic)*	(fmol)	(pic)*	(fmol)	
-OH	12	26,286,188	53.98	389,480	0.80	0.013
-OH	12	34,879,649	71.62			
-OH	14	539,486	1.07	45,197,674	89.32	0.011
-OH	14			54,409,947	107.53	

15 \* pic = relative phosphorimager counts

The data shown in Table 11 represent the results obtained with the following conditions: 5 min prehybridization at 70°C in 150 µl hybridization buffer; 1 min hybridization at 70°C in 200 µl hybridization buffer; 2 x washings for 2 min at 70°C with 800 µl of low stringency wash buffer; and 2 x washings for 5 min at 70°C with 800 µl of high stringency wash buffer.

20

Table 11. Quantification of captured oligonucleotides on membranes

Functional group	Probe	Oligonucleotide probe at capture oligonucleotide 12		Oligonucleotide probe at capture oligonucleotide 14		Average cross reactivity
		(pic)*	(fmol)	(pic)*	(fmol)	
on membrane						
-OH	12	5,032,835	10.33	56,777	0.12	0.012
-OH	12	4,569,483	9.38			
-OH	14	540,166	1.07	41,988,355	82.98	0.017
-OH	14			20,357,554	40.23	

\* pic = relative phosphorimager counts

5  
 These data demonstrate that hybridization of the capture oligonucleotide probes to their complementary sequences was specific. In comparison with the previous experiments performed with glass slides, significantly greater amounts (i.e., fmol quantities compared to amol quantities) of oligonucleotide probes were reproducibly captured on the membrane supports. For these two very closely-related capture oligonucleotide probes, average cross-reactivity values of about 1% could be obtained. However, for other pairs of capture oligonucleotides in the array, these values would be significantly better. In general, such values cannot be achieved by using existing methods that are known in the art, i.e., by allele-specific oligonucleotide hybridization ("ASO") or  
 15 by differential hybridization methods, such as sequencing by hybridization ("SBH").

#### Example 8 - Cleaning Glass Surfaces

20 Glass slides (Fisher Scientific, Extra thick microslides, frosted cat.# 12-550-11) were incubated in conc. aq.  $\text{NH}_4\text{OH-H}_2\text{O}_2\text{-H}_2\text{O}$  (1:1:5, v/v/v) at 80°C for 5 min and rinsed in distilled water. A second incubation was performed in conc. aq  $\text{HCl-H}_2\text{O}_2\text{-H}_2\text{O}$  (1:1:5, v/v/v) at 80°C for 5 min. See U. Jönsson, et al., "Absorption Behavior of Fibronectin on Well Characterized Silica Surfaces," *J. Colloid Interface Sci.* 90:148-163 (1982), which is hereby incorporated by reference. The slides were rinsed thoroughly in  
 25 distilled water, methanol, and acetone, and were air-dried at room temperature.

#### Example 9 - Silanization with 3-methacryloyloxypropyltrimethoxysilane

30 Cleaned slides, prepared according to Example 8, were incubated for 24-48 h at room temperature in a solution consisting of 2.6 ml of 3-methacryloyloxypropyltrimethoxysilane (Aldrich Chemical Company, Inc. Milwaukee, Wis. cat.# 23,579-2), 0.26 ml of triethylamine, and 130 ml of toluene. See E. Hedborg, et al., *Sensors Actuators A*, 37-38:796-799 (1993), which is hereby incorporated by

reference. The slides were rinsed thoroughly in acetone, methanol, distilled water, methanol again, and acetone again, and were air-dried at room temperature. See Figure 31.

5 **Example 10 - Silanization with dichlorodimethylsilane**

Cleaned slides, prepared according to Example 8, were incubated for 15 min at room temperature in a solution containing 12 ml of dichlorodimethylsilane and 120 ml of toluene. The slides were rinsed thoroughly in acetone, methanol, distilled water, methanol  
10 again, and acetone again and were air-dried.

**Example 11 - Polymerization of Poly(ethylene glycol)methacrylate with Methacrylate-derivatized Glass**

15 2.2 g of poly(ethylene glycol)methacrylate (Aldrich Chemical Company, Inc. Milwaukee, Wis. cat.# 40,953-7) (average M ~ 306 g/mol) and 50 mg of 2,2'-azobis(2-methylpropionitrile) in 3.5 ml of acetonitrile were cooled on ice and purged with a stream of argon for 3 min. The next steps were performed in a glovebox under argon atmosphere. 5-15 drops of the polymerization mixture were placed on a  
20 methacrylate-derivatized glass slide, prepared according to Examples 8 and 9. The methacrylate-derivatized glass slide and the polymerization mixture were covered by a second glass slide which had been silanized according to Example 10, and the two glass slides were pressed together and fixed with clips. The slides were subsequently transferred to a vacuum desiccator. The polymerization was thermolytically initiated at  
25 55°C, or photolytically at 366 nm. See Figure 32.

**Example 12 - Polymerization of Acrylic Acid and Trimethylolpropane Ethoxylate (14/3 EO/OH) Triacrylate with Methacrylate-Derivatized Glass**

30 0.5 g of acrylic acid (Aldrich Chemical Company, Inc. Milwaukee, Wis. cat.# 14,723-0), 1.83 g of trimethylolpropane ethoxylate (14/3 EO/OH) triacrylate (Aldrich Chemical Company, Inc. Milwaukee, Wis. cat.# 23,579-2) and 50 mg of 2,2'-azobis(2-methylpropionitrile) in 3.5 ml of acetonitrile were cooled on ice and purged with a stream of argon for 3 min. The next steps were performed in a glovebox as  
35 described in Example 11. The slides were subsequently transferred to a vacuum desiccator and polymerized as described in Example 11. See Figure 33.

**Example 13 - Polymerization of Poly(ethylene glycol)methacrylate and  
Trimethylolpropane Ethoxylate (14/3 EO/OH) Triacrylate with  
Methacrylate-derivatized Glass**

5           0.55 g of poly(ethylene glycol)methacrylate (Aldrich Chemical Company, Inc.  
Milwaukee, Wis. cat.# 40,953.7), 1.64 g of trimethylolpropane ethoxylate (14/3 EO/OH  
triacrylate (Aldrich Chemical Company, Inc. Milwaukee, Wis. cat.# 23,579-2), and 50 mg  
of 2,2'-azobis(2-methylpropionitrile) in 3.5 ml of acetonitrile were cooled on ice and  
10           purged with a stream of argon for 3 min. The next steps were performed in a glove-box as  
described in Example 11. The slides were subsequently transferred to a vacuum desiccator  
and polymerized as described in Example 11. See Figure 34.

          Although the invention has been described in detail for the purpose of illustration,  
it is understood that such details are solely for that purpose and variations can be made  
therein by those skilled in the art without departing from the spirit and scope of the  
15           invention which is defined by the following claims.



**WHAT IS CLAIMED:**

1. A method for identifying one or more of a plurality of sequences differing by one or more single-base changes, insertions, deletions, or translocations in a plurality of target nucleotide sequences comprising:
  - 5 providing a sample potentially containing one or more target nucleotide sequences with a plurality of sequence differences;
  - providing a plurality of oligonucleotide probe sets, each set characterized by (a) a first oligonucleotide probe, having a target-specific portion and an addressable array-specific portion, and (b) a second oligonucleotide probe, having a target-specific portion and a detectable reporter label, wherein the oligonucleotide probes in a particular set are suitable for ligation together when hybridized adjacent to one another on a corresponding target nucleotide sequence, but have a mismatch which interferes with such ligation when hybridized to any other nucleotide sequence present in the sample;
  - 15 providing a ligase,
  - blending the sample, the plurality of oligonucleotide probe sets, and the ligase to form a mixture;
  - subjecting the mixture to one or more ligase detection reaction cycles comprising a denaturation treatment, wherein any hybridized oligonucleotides are separated from the target nucleotide sequences, and a hybridization treatment, wherein the oligonucleotide probe sets hybridize at adjacent positions in a base-specific manner to their respective target nucleotide sequences, if present in the sample, and ligate to one another to form a ligated product sequence containing (a) the addressable array-specific portion, (b) the target-specific portions connected together, and (c) the detectable reporter label, and, wherein the oligonucleotide probe sets may hybridize to nucleotide sequences in the sample other than their respective target nucleotide sequences but do not ligate together due to a presence of one or more mismatches and individually separate during the denaturation treatment;
  - providing a solid support with different capture oligonucleotides immobilized at particular sites, wherein the capture oligonucleotides have nucleotide sequences complementary to the addressable array-specific portions;
  - 30 contacting the mixture, after said subjecting, with the solid support under conditions effective to hybridize the addressable array-specific portions to the capture oligonucleotides in a base-specific manner, thereby capturing the addressable array-specific portions on the solid support at the site with the complementary capture oligonucleotide; and
  - detecting the reporter labels of ligated product sequences captured to the solid support at particular sites, thereby indicating the presence of one or more target nucleotide sequences in the sample.
- 40 2. A method according to claim 1, wherein the oligonucleotide probes in a set are suitable for ligation together at a ligation junction when hybridized adjacent to one

another on a corresponding target nucleotide sequence due to perfect complementarity at the ligation junction, but, when the oligonucleotide probes in the set are hybridized to any other nucleotide sequence present in the sample, have a mismatch at a base at the ligation junction which interferes with such ligation.

5

3. A method according to claim 2, wherein the mismatch is at the 3' base at the ligation junction.

4. A method according to claim 1, wherein the oligonucleotide probes in a set are suitable for ligation together at a ligation junction when hybridized adjacent to one another on a corresponding target nucleotide sequence due to perfect complementarity at the ligation junction, but, when the oligonucleotide probes in the set are hybridized to any other nucleotide sequence present in the sample, there is a mismatch at a base adjacent to a base at the ligation junction which interferes with such ligation.

15

5. A method according to claim 4, wherein the mismatch is at the base adjacent to the 3' base at the ligation junction.

6. A method according to claim 1, wherein the sample potentially contains unknown amounts of one or more of a plurality of target sequences with a plurality of sequence differences, said method further comprising:  
quantifying, after said detecting, the amount of the target nucleotide sequences in the sample by comparing the amount of captured ligated product sequences generated from the sample with a calibration curve of captured ligated product sequences generated from samples with known amounts of the target nucleotide sequence.

25

7. A method according to claim 1, wherein the sample potentially contains unknown amounts of one or more of a plurality of target nucleotide sequences with a plurality of sequence differences, said method further comprising:

30 providing a known amount of one or more marker target nucleotide sequences;

providing a plurality of marker-specific oligonucleotide probe sets, each set characterized by (a) a first oligonucleotide probe, having a target-specific portion complementary to the marker target nucleotide sequence and an addressable array-specific portion complementary to capture oligonucleotides on the solid support, and (b) a second oligonucleotide probe, having a target-specific portion complementary to the marker target nucleotide sequence and a detectable reporter label, wherein the oligonucleotide probes in a particular marker-specific oligonucleotide set are suitable for ligation together when hybridized adjacent to one another on a corresponding marker target nucleotide sequence, but, when hybridized to any other nucleotide sequence present in the sample or added

40

marker sequences, there is a mismatch which interferes with such ligation, wherein said blending comprises blending the sample, the marker target nucleotide sequences, the plurality of oligonucleotide probe sets, the plurality of marker-specific oligonucleotide probe sets, and the ligase to form a mixture;

5 detecting the reporter labels of the ligated marker-specific oligonucleotide sets captured on the solid support at particular sites, thereby indicating the presence of one or more marker target nucleotide sequences in the sample; and

quantifying the amount of target nucleotide sequences in the sample by comparing the amount of captured ligated product generated from the known amount of  
10 marker target nucleotide sequences with the amount of captured other ligated product.

8. A method according to claim 7, wherein the one or more marker target nucleotide sequences differ from the target nucleotide sequences in the sample at one or more single nucleotide positions.

15

9. A method according to claim 8, wherein the oligonucleotide probe sets and the marker-specific oligonucleotide probe sets form a plurality of oligonucleotide probe groups, each group comprised of one or more oligonucleotide probe sets designed for distinguishing multiple allele differences at a single nucleotide position, wherein, in the  
20 oligonucleotide probe sets of each group, the first oligonucleotide probes have a common target-specific portion, and the second oligonucleotide probes have a differing target-specific portion which hybridize to a given allele or a marker nucleotide sequence in a base-specific manner.

25 10. A method according to claim 8, wherein the oligonucleotide probe sets and the marker-specific oligonucleotide probe sets form a plurality of oligonucleotide probe groups, each group comprised of one or more oligonucleotide probe sets designed for distinguishing multiple allele differences at a single nucleotide position, wherein, in the oligonucleotide probe sets of each group, the second oligonucleotide probes have a  
30 common target-specific portion and the first oligonucleotide probe have differing target-specific portions, which hybridize to a given allele or a marker nucleotide sequence in a base-specific manner.

11. A method according to claim 1, wherein the sample potentially contains  
35 unknown amounts of two or more of a plurality of target nucleotide sequences with a plurality of sequence differences, said method further comprising:

quantifying, after said detecting, the relative amount of each of the plurality of target nucleotide sequences in the sample by comparing the relative amount of captured ligated product sequences generated by each of the plurality of target sequences within the

sample, thereby providing a quantitative measure of the relative level of two or more target nucleotide sequences in the sample.

12. A method according to claim 1, wherein multiple allele differences at two  
5 or more nearby or adjacent nucleotide positions in a single target nucleotide sequence or multiple allele differences at two or more nearby or adjacent nucleotide positions in multiple target nucleotide sequences are distinguished with oligonucleotide probe sets having oligonucleotide probes with target-specific portions which overlap.

10 13. A method according to claim 1, wherein the target-specific portions of the oligonucleotide probe sets have substantially the same melting temperature so that they hybridize to target nucleotide sequences under similar hybridization conditions.

14. A method according to claim 1, wherein multiple allele differences at one  
15 or more nucleotide position in a single target nucleotide sequence or multiple allele differences at one or more positions in multiple target nucleotide sequences are distinguished, the oligonucleotide probe sets forming a plurality of oligonucleotide probe groups, each group comprised of one or more oligonucleotide probe sets designed for distinguishing multiple allele differences at a single nucleotide position, wherein, in the  
20 oligonucleotide probes of each group, the second oligonucleotide probes have a common target-specific portion and the first oligonucleotide probes have differing target-specific portions which hybridize to a given allele in a base-specific manner, wherein, in said detecting, the labels of ligated product sequences of each group, captured on the solid support at different sites, are detected, thereby indicating a presence, in the sample of one  
25 or more allele at one or more nucleotide position in one or more target nucleotide sequences.

15. A method according to claim 14, wherein the oligonucleotide probes in a  
given set are suitable for ligation together at a ligation junction when hybridized adjacent  
30 to one another on a corresponding target nucleotide sequence due to perfect complementarity at the ligation junction, but, when hybridized to any other nucleotide sequence present in the sample, the first oligonucleotide probe has a mismatch at a base at the ligation junction which interferes with such ligation.

35 16. A method according to claim 14, wherein multiple allele differences at two or more nearby or adjacent nucleotide positions in a single target nucleotide sequence or multiple allele differences at two or more nearby or adjacent nucleotide positions in multiple target nucleotide sequences are distinguished with oligonucleotide probe groups having oligonucleotide probes with target-specific portions which overlap.

40

17. A method according to claim 16, wherein the oligonucleotide probes in a set are suitable for ligation together at a ligation junction when hybridized adjacent to one another on a corresponding target nucleotide sequence due to perfect complementarity at the ligation junction, but, when the oligonucleotide probes in the set are hybridized to any other nucleotide sequence present in the sample, there is a mismatch at a base at the ligation junction which interferes with such ligation.

18. A method according to claim 1, wherein multiple allele differences consisting of insertions, deletions, microsatellite repeats, translocations, or other DNA rearrangements at one or more nearby positions in a single target nucleotide sequence or multiple allele differences consisting of insertions, deletions, microsatellite repeats, translocations, or other DNA rearrangements at one or more nearby positions in multiple target nucleotide sequences are distinguished, the oligonucleotide probe sets forming a plurality of oligonucleotide probe groups, each group comprised of one or more oligonucleotide probe sets designed for distinguishing multiple allele differences selected from the group consisting of insertions, deletions, microsatellite repeats, translocations, and other DNA rearrangements at one or more nearby positions, wherein, in the oligonucleotide probe sets of each group, the second oligonucleotide probes have a common target-specific portion and the first oligonucleotide probes have differing target-specific portions which hybridize to a given allele in a base-specific manner, wherein, in said detecting, the labels of ligated product sequences of each group, captured on the solid support at different sites, are detected, thereby indicating a presence, in the sample, of one or more allele differences selected from the group consisting of insertions, deletions, microsatellite repeats, translocations, and other DNA rearrangements in one or more target nucleotide sequences.

19. A method according to claim 18, wherein the oligonucleotide probe sets are designed for distinguishing multiple allele differences selected from the group consisting of insertions, deletions, and microsatellite repeats, at one or more nearby positions, wherein, in the oligonucleotide probe sets of each group, the second oligonucleotide probes have a common target-specific portion, and the first oligonucleotide probes have differing target-specific portions which contain repetitive sequences of different lengths to hybridize to a given allele in a base-specific manner.

20. A method according to claim 1, wherein a low abundance of multiple allele differences at multiple nearby or adjacent positions in a single target nucleotide sequence, in the presence of an excess of normal sequence, or a low abundance of multiple allele differences at multiple nearby positions in multiple target nucleotide sequences, in the presence of an excess of normal sequence, are distinguished, the oligonucleotide probe sets forming a plurality of oligonucleotide probe groups, each group comprised of one or

more oligonucleotide probe sets designed for distinguishing multiple allele differences at a single nucleotide position, wherein one or more sets within a group share common second oligonucleotide probes and the first oligonucleotide probes have differing target-specific portions which hybridize to a given allele excluding the normal allele in a base-specific manner, wherein, in said detecting, the labels of ligated product sequences of each group captured on the solid support at different sites, are detected, thereby indicating a presence, in the sample, of one or more low abundance alleles at one or more nucleotide positions in one or more target nucleotide sequences.

21. A method according to claim 20, wherein the oligonucleotide probes in a set are suitable for ligation together at a ligation junction when hybridized adjacent to one another on a corresponding target nucleotide sequence due to perfect complementarity at the ligation junction, but, when the oligonucleotide probes in the set are hybridized to any other nucleotide sequence present in the sample, the first oligonucleotide probes have a mismatch at a base at the ligation junction which interferes with such ligation.

22. A method according to claim 20, wherein a low abundance of multiple allele differences at multiple nearby or adjacent positions in a single target nucleotide sequence, in the presence of an excess of normal sequence, or a low abundance of multiple allele differences at multiple nearby positions in multiple target nucleotide sequences, in the presence of an excess of normal sequence, are quantified in a sample, said method further comprising:

providing a known amount of one or more marker target nucleotide sequences;

25 providing a plurality of marker-specific oligonucleotide probe sets, each set characterized by (a) a first oligonucleotide probe having a target-specific portion complementary to the marker target nucleotide sequence and an addressable array-specific portion, and (b) a second oligonucleotide probe, having a target-specific portion complementary to the marker target nucleotide sequence and a detectable reporter label, wherein the oligonucleotide probes in a particular marker-specific oligonucleotide set are suitable for ligation together when hybridized adjacent to one another on a corresponding marker target nucleotide sequence, but, when hybridized to any other nucleotide sequence present in the sample or added marker sequences, have a mismatch which interferes with such ligation;

35 providing a plurality of oligonucleotide probe groups, each group comprised of one or more oligonucleotide probe sets or marker-specific oligonucleotide probe sets designed for distinguishing multiple allele differences at a single nucleotide position, including marker nucleotide sequences, wherein one or more sets within a group share a common second oligonucleotide probe and the first oligonucleotide probes have different target-specific probe portions which hybridize to a given allele or a marker

nucleotide sequence excluding the normal allele, in a base-specific manner, wherein said blending comprises blending the sample, the marker target nucleotide sequences, the plurality of oligonucleotide probe sets, the plurality of marker-specific oligonucleotide probe sets, and the ligase to form a mixture;

5 detecting the reporter labels of the ligated marker-specific oligonucleotide sets captured on the solid support at particular sites, thereby indicating the presence of one or more marker target nucleotide sequences in the sample; and

quantifying the amount of target nucleotide sequences in the sample by comparing the amount of captured ligated products generated from the known amount of  
10 marker target nucleotide sequences with the amount of other captured ligated product generated from the low abundance unknown sample.

23. A method according to claim 22, wherein the oligonucleotide probes in a set are suitable for ligation together at a ligation junction when hybridized adjacent to one  
15 another on a corresponding target nucleotide sequence under selected conditions due to perfect complementarity at the ligation junction, but, when the oligonucleotide probes in the set are hybridized to any other nucleotide sequence present in the sample, the first oligonucleotide probes have a mismatch at a base at the ligation junction which interferes with such ligation.

20  
24. A method according to claim 1, wherein multiple allele differences at one or more nucleotide position in a single target nucleotide sequence or multiple allele differences at one or more positions in multiple target nucleotide sequences are distinguished, the oligonucleotide sets forming a plurality of oligonucleotide probe  
25 groups. each group comprised of one or more oligonucleotide probe sets designed for distinguishing multiple allele differences at a single nucleotide position, wherein, in the oligonucleotide probes of each group, the first oligonucleotide probes have a common target-specific portion and the second oligonucleotide probes have differing target-specific  
portions which hybridize to a given allele in a base-specific manner, wherein, in said  
30 detecting, different reporter labels of ligated product sequences of each group captured on the solid support at particular sites are detected, thereby indicating a presence, in the sample, of one or more allele at one or more nucleotide positions in one or more target nucleotide sequences.

35 25. A method according to claim 24, wherein the oligonucleotide probes in a set are suitable for ligation together at a ligation junction when hybridized adjacent to one another on a corresponding target nucleotide sequence due to perfect complementarity at the ligation junction, but, when the oligonucleotide probes in the set are hybridized to any other nucleotide sequence present in the sample, the second oligonucleotide probes have a  
40 mismatch at a base at the ligation junction which interferes with such ligation.

26. A method according to claim 24, wherein multiple allele differences at two or more nearby or adjacent nucleotide positions in a single target nucleotide sequence, or multiple allele differences at two or more nearby or adjacent nucleotide positions in multiple target nucleotide sequences are distinguished, the oligonucleotide probe groups  
5 containing oligonucleotide probes with target-specific portions which overlap.

27. A method according to claim 26, wherein the oligonucleotide probes in a set are suitable for ligation together at a ligation junction when hybridized adjacent to one another on a corresponding target nucleotide sequence due to perfect complementarity at  
10 the ligation junction, but, when the oligonucleotide probes in the set are hybridized to any other nucleotide sequence present in the sample, the second oligonucleotide probe has a mismatch at a base at the ligation junction which interferes with such ligation.

28. A method according to claim 1, wherein multiple allele differences at one  
15 or more nucleotide position in a single target nucleotide sequence or multiple allele differences at one or more positions in multiple target nucleotide sequences are distinguished, the oligonucleotide sets forming a plurality of probe groups, each group comprised of one or more oligonucleotide probe sets designed for distinguishing multiple  
20 allele differences at a single nucleotide position, wherein, in the oligonucleotide probes of different groups, the second oligonucleotide probes have a common target-specific portion or the first oligonucleotide probes have a common target-specific portion, wherein, in said detecting, the one of a plurality of labeled ligated product sequences of each group  
25 captured on the solid support at particular sites are detected, thereby indicating a presence of one or more allele at one or more nucleotide positions in one or more target nucleotide sequences in the sample.

29. A method according to claim 28, wherein the oligonucleotide probes in a given set are suitable for ligation together at ligation junction when hybridized adjacent to  
30 one another on a corresponding target nucleotide sequence due to perfect complementarity at the ligation junction but, when the oligonucleotides in the set are hybridized to any other nucleotide sequence present in the sample, the first or second oligonucleotide probes have a mismatch at a base at the ligation junction which interferes with such ligation.

30. A method according to claim 28, wherein multiple allele differences at two  
35 or more nearby or adjacent nucleotide positions in a target nucleotide sequence or multiple allele differences at two or more nearby or adjacent nucleotide positions in multiple target nucleotide sequence are distinguished, the oligonucleotide probe groups containing probes with target-specific portions which overlap.

40



31. A method according to claim 30, wherein oligonucleotide probes in a set are suitable for ligation together at a ligation junction when hybridized adjacent to one another on a corresponding target nucleotide sequence due to perfect complementarity at the ligation junction, but, when the oligonucleotides in the set are hybridized to any other  
5 nucleotide sequence present in the sample, the first or second oligonucleotide probes have a mismatch at a base at the ligation junction which interferes with such ligation.

32. A method according to claim 29, wherein all possible single-base mutations for a single codon in a single target nucleotide sequence, all possible single-base mutations  
10 for multiple codons in a single target nucleotide sequence, and all possible single-base mutations for multiple codons in multiple target nucleotide sequences are distinguished, the oligonucleotide sets forming a plurality of oligonucleotide probe groups, each group comprised of one or more oligonucleotide probe sets designed for distinguishing all possible single-base mutations for a single codon, wherein, in the oligonucleotide probes  
15 of each group, the second oligonucleotide probes differ only in their 5' bases at their ligation junction and contain different reporter labels, the first oligonucleotide probes differ only in their 3' bases at their ligation junction and contain different addressable array-specific portions, or the first oligonucleotide probes differ only in their 3' bases adjacent to the base at the ligation junction and contain different addressable array-specific  
20 portions.

33. A method according to claim 29, wherein the oligonucleotide probes in a set are suitable for ligation together at a ligation junction when hybridized adjacent to one another on a corresponding target nucleotide sequence due to perfect complementarity at the ligation junction, but, when the oligonucleotides in the set are hybridized to any other  
25 nucleotide sequence present in the sample, the first oligonucleotide probes have a mismatch at the 3' base at the ligation junction or the 3' base adjacent the base at the ligation junction or the second oligonucleotide probes have a mismatch at the 5' base at the ligation junction which interferes with such ligation.

34. A method according to claim 33, wherein all possible single-base mutations for a single codon in a single target nucleotide sequence, or all possible single-base mutations for two or more nearby or adjacent codons in multiple target nucleotide sequences are distinguished, the oligonucleotide probe groups containing oligonucleotide probes with target-specific portions which overlap.  
35

35. A method according to claim 1, wherein the denaturation treatment is at a temperature of about 80°-105°C.

36. A method according to claim 1, wherein each cycle, comprising a denaturation treatment and a hybridization treatment, is from about 30 seconds to about five minutes long.
- 5 37. A method according to claim 1, wherein said subjecting is repeated for 2 to 50 cycles.
38. A method according to claim 1, wherein total time for said subjecting is 1 to 250 minutes.
- 10 39. A method according to claim 1, wherein the ligase is selected from the group consisting of *Thermus aquaticus* ligase, *Thermus thermophilus* ligase, *E. coli* ligase, T4 ligase, and *Pyrococcus* ligase.
- 15 40. A method according to claim 1, wherein the detectable reporter label is selected from the group consisting of chromophores, fluorescent moieties, enzymes, antigens, heavy metals, magnetic probes, dyes, phosphorescent groups, radioactive materials, chemiluminescent moieties, and electrochemical detecting moieties.
- 20 41. A method according to claim 1, wherein the target-specific portions of the oligonucleotide probes each have a hybridization temperature of 20-85°C.
42. A method according to claim 1, wherein the target-specific portions of the oligonucleotide probes are 20 to 28 nucleotides long.
- 25 43. A method according to claim 1, wherein the mixture further includes a carrier DNA.
44. A method according to claim 1, wherein said subjecting achieves a rate of formation of mismatched ligated product sequences which is less than .005 of the rate of formation of matched ligated product sequences.
- 30 45. A method according to claim 1 further comprising:  
amplifying the target nucleotide sequences in the sample prior to said  
35 blending.
46. A method according to claim 45, wherein said amplifying is carried out by subjecting the sample to a polymerase-based amplifying procedure.

47. A method according to claim 45, wherein said polymerase-based amplifying procedure is carried out with DNA polymerase.

48. A method according to claim 45, wherein said polymerase-based amplifying procedure is carried out with reverse transcriptase.

49. A method according to claim 45, wherein said polymerase-based amplifying procedure is carried out with RNA polymerase.

50. A method according to claim 45, wherein said amplifying is carried out by subjecting the target nucleotide sequences in the sample to a ligase chain reaction process.

51. A method according to claim 1, wherein the oligonucleotide probe sets are selected from the group consisting of ribonucleotides, deoxyribonucleotides, modified ribonucleotides, modified deoxyribonucleotides, peptide nucleic acids, modified peptide nucleic acids, modified phosphate-sugar backbone oligonucleotides, nucleotide analogues, and mixtures thereof.

52. A method according to claim 1, wherein said method is used to detect infectious diseases caused by bacterial, viral, parasitic, and fungal infectious agents.

53. A method according to claim 52, wherein the infectious disease is caused by a bacteria selected from the group consisting of *Escherichia coli*, *Salmonella*, *Shigella*, *Klebsiella*, *Pseudomonas*, *Listeria monocytogenes*, *Mycobacterium tuberculosis*, *Mycobacterium avium-intracellulare*, *Yersinia*, *Francisella*, *Pasteurella*, *Brucella*, *Clostridia*, *Bordetella pertussis*, *Bacteroides*, *Staphylococcus aureus*, *Streptococcus pneumoniae*, B-Hemolytic strep., *Corynebacteria*, *Legionella*, *Mycoplasma*, *Ureaplasma*, *Chlamydia*, *Neisseria gonorrhoea*, *Neisseria meningitidis*, *Hemophilus influenzae*, *Enterococcus faecalis*, *Proteus vulgaris*, *Proteus mirabilis*, *Helicobacter pylori*, *Treponema palladium*, *Borrelia burgdorferi*, *Borrelia recurrentis*, *Rickettsial* pathogens, *Nocardia*, and *Acitnomycetes*.

54. A method according to claim 52, wherein the infectious disease is caused by a fungal infectious agent selected from the group consisting of *Cryptococcus neoformans*, *Blastomyces dermatitidis*, *Histoplasma capsulatum*, *Coccidioides immitis*, *Paracoccidioides brasiliensis*, *Candida albicans*, *Aspergillus fumigatus*, *Phycomycetes* (*Rhizopus*), *Sporothrix schenckii*, *Chromomycosis*, and *Maduromycosis*.

55. A method according to claim 52, wherein the infectious disease is caused by a viral infectious agent selected from the group consisting of human immunodeficiency

virus, human T-cell lymphocytotropic viurs, hepatitis viruses (e.g., Hepatitis B Virus and Hepatitis C Virus), Epstein-Barr Virus, cytomegalovirus, human papillomaviruses, orthomyxo viruses, paramyxo viruses, adenoviruses, corona viruses, rhabdo viruses, polio viruses, toga viruses, bunya viruses, arena viruses, rubella viruses, and reo viruses.

5

56. A method according to claim 52, wherein the infectious disease is caused by a parasitic infectious agent selected from the group consisting of *Plasmodium falciparum*, *Plasmodium malaria*, *Plasmodium vivax*, *Plasmodium ovale*, *Onchoverva volvulus*, *Leishmania*, *Trypanosoma* spp., *Schistosoma* spp., *Entamoeba histolytica*,

10 *Cryptosporidium*, *Giardia* spp., *Trichimonas* spp., *Balatidium coli*, *Wuchereria bancrofti*, *Toxoplasma* spp., *Enterobius vermicularis*, *Ascaris lumbricoides*, *Trichuris trichiura*, *Dracunculus medinensis*, trematodes, *Diphyllobothrium latum*, *Taenia* spp., *Pneumocystis carinii*, and *Necator americanis*.

15 57. A method according to claim 1, wherein said method is used to detect genetic diseases.

58. A method according to claim 57, wherein the genetic disease is selected from the group consisting of 21 hydroxylase deficiency, cystic fibrosis, Fragile X  
20 Syndrome, Turner Syndrome, Duchenne Muscular Dystrophy, Down Syndrome, heart disease, single gene diseases, HLA typing, phenylketonuria, sickle cell anemia, Tay-Sachs Syndrome, thalassemia, Klinefelter's Syndrome, Huntington's Disease, autoimmune diseases, lipidosis, obesity defects, hemophilia, inborn errors in metabolism, and diabetes.

25 59. A method according to claim 1, wherein said method is used to detect cancer involving oncogenes, tumor suppressor genes, or genes involved in DNA amplification, replication, recombination, or repair.

60. A method according to claim 59, wherein the cancer is associated with a  
30 gene selected from the group consisting of BRCA1 gene, p53 gene, *Familial polyposis coli*, Her2/Neu amplification, Bcr/Ab1, K-ras gene, human papillomavirus Types 16 and 18, leukemia, colon cancer, breast cancer, lung cancer, prostate cancer, brain tumors, central nervous system tumors, bladder tumors, melanomas, liver cancer, osteosarcoma and other bone cancers, testicular and ovarian carcinomas, ENT tumors, and loss of  
35 heterozygosity.

61. A method according to claim 1, wherein said method is used for environmental monitoring, forensics, and food and feed industry monitoring.

62. A method according to claim 1, wherein the solid support is made from a material selected from the group consisting of plastic, ceramic, metal, resin, gel, glass, silicon, and composites thereof.

5 63. A method according to claim 1, wherein the solid support is in a form selected from the group consisting of slides, discs, membranes, films, and composites thereof.

64. A method according to claim 1, wherein the solid support has an array of  
10 positions with the capture oligonucleotides attached to positions in the array.

65. A method according to claim 64, wherein the solid support has wells, raised regions, or etched trenches.

15 66. A method according to claim 64, wherein the solid support is in the form of a microtiter plate.

67. A method according to claim 1, wherein the solid support is functionalized with olefin, amino, hydroxyl, silanol, aldehyde, keto, halo, acyl halide, or carboxyl groups.  
20

68. A method according to claim 67, wherein the solid support is functionalized with an amino group by reaction with an amine compound selected from the group consisting of 3-aminopropyl triethoxysilane, 3-aminopropylmethyldiethoxysilane, 3-aminopropyl dimethylethoxysilane, 3-aminopropyl trimethoxysilane, N-(2-aminoethyl)-3-aminopropylmethyl dimethoxysilane, N-(2-aminoethyl-3-aminopropyl) trimethoxysilane, aminophenyl trimethoxysilane, 4-aminobutyldimethyl methoxysilane, 4-aminobutyl triethoxysilane, aminoethylaminomethylphenethyl trimethoxysilane, and mixtures thereof.  
25

30 69. A method according to claim 67, wherein the solid support is functionalized with an olefin-containing silane.

70. A method according to claim 69, wherein the olefin-containing silane is selected from the group consisting of 3-(trimethoxysilyl)propyl methacrylate, N-[3-(trimethoxysilyl)propyl]-N'-(4-vinylbenzyl)ethylenediamine, triethoxyvinylsilane, triethylvinylsilane, vinyltrichlorosilane, vinyltrimethoxysilane, vinyltrimethylsilane, and mixtures thereof.  
35

71. A method according to claim 69 wherein the silanized support is  
40 polymerized with an olefin containing monomer.

72. A method according to claim 71, wherein the olefin-containing monomer contains a functional group.

73. A method according to claim 72, wherein the olefin-containing monomer is selected from the group consisting of acrylic acid, methacrylic acid, vinylacetic acid, 4-vinylbenzoic acid, itaconic acid, allyl amine, allylethylamine, 4-aminostyrene, 2-aminoethyl methacrylate, acryloyl chloride, methacryloyl chloride, chlorostyrene, dichlorostyrene, 4-hydroxystyrene, hydroxymethylstyrene, vinylbenzyl alcohol, allyl alcohol, 2-hydroxyethyl methacrylate, poly(ethylene glycol) methacrylate, and mixtures thereof.

74. A method according to claim 71, wherein the support is polymerized with a monomer selected from the group consisting of acrylic acid, methacrylic acid, vinylacetic acid, 4-vinylbenzoic acid, itaconic acid, allyl amine, allylethylamine, 4-aminostyrene, 2-aminoethyl methacrylate, acryloyl chloride, methacryloyl chloride, chlorostyrene, dichlorostyrene, 4-hydroxystyrene, hydroxymethyl styrene, vinylbenzyl alcohol, allyl alcohol, 2-hydroxyethyl methacrylate, poly(ethylene glycol) methacrylate, and mixtures thereof, together with a monomer selected from the group consisting of acrylic acid, acrylamide, methacrylic acid, vinylacetic acid, 4-vinylbenzoic acid, itaconic acid, allyl amine, allylethylamine, 4-aminostyrene, 2-aminoethyl methacrylate, acryloyl chloride, methacryloyl chloride, chlorostyrene, dichlorostyrene, 4-hydroxystyrene, hydroxymethyl styrene, vinylbenzyl alcohol, allyl alcohol, 2-hydroxyethyl methacrylate, poly(ethylene glycol) methacrylate, methyl acrylate, methyl methacrylate, ethyl acrylate, ethyl methacrylate, styrene, 1-vinylimidazole, 2-vinylpyridine, 4-vinylpyridine, divinylbenzene, ethylene glycol dimethacrylate, *N,N*-methylenediacylamide, *N,N*-phenylenediacylamide, 3,5-bis(acryloylamido) benzoic acid, pentaerythritol triacrylate, trimethylolpropane trimethacrylate, pentaerythritol tetraacrylate, trimethylolpropane ethoxylate (14/3 EO/OH) triacrylate, trimethylolpropane ethoxylate (7/3 EO/OH) triacrylate, trimethylolpropane propoxylate (1 PO/OH) triacrylate, trimethylolpropane propoxylate (2 PO/OH) triacrylate, and mixtures thereof.

75. A method according to claim 1, wherein said detecting comprises:  
scanning the solid support at the particular sites and identifying if ligation of the oligonucleotide probe sets occurred and  
correlating identified ligation to a presence or absence of the target nucleotide sequences.

76. A method according to claim 75, wherein said scanning is carried out by scanning electron microscopy, electron microscopy, confocal microscopy, charge-coupled

device, scanning tunneling electron microscopy, infrared microscopy, atomic force microscopy, electrical conductance, and fluorescent or phosphor imaging.

5 77. A method according to claim 75, wherein said correlating is carried out with a computer.

78. A method according to claim 1, wherein said contacting the mixture with the solid support is at a temperature of 45-90°C and for a time period of up to 60 minutes.

10 79. A method according to claim 1, wherein some of the plurality of capture oligonucleotides have identical nucleotide sequences and different labels are used for some different target nucleotide sequence.

15 80. A method according to claim 1, wherein the plurality of capture oligonucleotides each have different nucleotide sequences.

20 81. A method according to claim 80, wherein each capture oligonucleotide differs from its adjacent capture oligonucleotide on the array by at least 25% of the nucleotides.

25 82. A method according to claim 80, wherein each capture oligonucleotide has adjacent capture oligonucleotides separated from adjacent capture oligonucleotides by barrier oligonucleotides to which ligated oligonucleotide probe sets will not hybridize during said contacting.

30 83. A method according to claim 1, wherein the oligonucleotide probe sets hybridize to the target nucleotide sequences at temperatures which are less than that at which the capture oligonucleotides hybridize to the addressable array-specific portion of oligonucleotide probe sets.

35 84. A method according to claim 1 further comprising:  
treating the mixture chemically or enzymatically, after said subjecting the mixture to a series of ligase detection reaction cycles, to destroy unligated oligonucleotide probes.

85. A method according to claim 84, wherein said treating is carried out with an exonuclease.

86. A method according to claim 1 further comprising:  
removing oligonucleotides bound to the capture oligonucleotides to permit  
reuse of the solid support with immobilized capture oligonucleotides.

5 87. A method according to claim 1, wherein the solid support includes different  
capture oligonucleotides immobilized at different sites with different capture  
oligonucleotides being complementary to different addressable array-specific portions,  
whereby different oligonucleotide probe sets are captured and detected at different sites on  
the solid support.

10 88. A method according to claim 1, wherein the solid support includes identical  
capture oligonucleotides immobilized on the solid support with the capture  
oligonucleotides being complementary to all the addressable array-specific portions and  
the labels attached to the oligonucleotide probe sets being different, whereby the different  
15 oligonucleotide probe sets are detected and distinguished by the different labels.

89. A method of forming arrays of oligonucleotides on a solid support  
comprising:  
providing a solid support having an array of positions each suitable for  
20 attachment of an oligonucleotide;  
attaching to the solid support a surface or linker, suitable for coupling an  
oligonucleotide to the solid support, at each of the array positions; and  
forming the array of a plurality of capture oligonucleotides on the solid  
support by a series of cycles of activating selected array positions for attachment of  
25 multimer nucleotides and attaching multimer nucleotides at the activated array positions.

90. A method according to claim 89, wherein said forming comprises:  
applying a multimer nucleotide along parallel rows of the solid  
support;  
30 turning the support 90 degrees;  
attaching a multimer nucleotide along parallel rows of the solid support to  
form oligonucleotides at row intersections having 2 sets of multimer nucleotides; and  
repeating said applying, turning, and attaching until the oligonucleotides at  
the row intersections have 6 sets of multimer nucleotides.

35 91. A method according to claim 89, wherein the solid support is made from a  
material selected from the group consisting of plastic, ceramic, metal, resin, gel, glass,  
silicon, and composites thereof.



92. A method according to claim 89, wherein the solid support is in a form selected from the group consisting of slides, discs, membranes, films, and composites thereof.
- 5 93. A method according to claim 89, wherein the solid support has an array of positions with the plurality of capture oligonucleotides having different nucleotide sequences.
94. A method according to claim 93, wherein the solid support has wells, raised  
10 regions, or etched trenches.
95. A method according to claim 94, wherein the solid support is in the form of a microtiter plate.
- 15 96. A method according to claim 89, wherein said attaching a linker comprises: silanizing a surface of the solid support.
97. A method according to claim 89, wherein the solid support is  
functionalized with olefin, amino, hydroxyl, silanol, aldehyde, keto, halo, acyl halide, or  
20 carboxyl groups.
98. A method according to claim 97, wherein the solid support is  
functionalized with an amino group by reaction with an amine compound selected from  
the group consisting of 3-aminopropyl triethoxysilane, 3-  
25 aminopropylmethyldiethoxysilane, 3-aminopropyl dimethylethoxysilane, 3-aminopropyl  
trimethoxysilane, N-(2-aminoethyl)-3-aminopropylmethyl dimethoxysilane, N-(2-  
aminoethyl-3-aminopropyl) trimethoxysilane, aminophenyl trimethoxysilane, 4-  
aminobutyldimethyl methoxysilane, 4-aminobutyl triethoxysilane,  
aminoethylaminomethylphenethyl trimethoxysilane, and mixtures thereof.  
30
99. A method according to claim 97, wherein the solid support is  
functionalized with an olefin-containing silane.
100. A method according to claim 99, wherein the olefin-containing silane is  
35 selected from the group consisting of 3-(trimethoxysilyl)propyl methacrylate, N-[3-  
(trimethoxysilyl)propyl]-N-(4-vinylbenzyl)ethylenediamine, triethoxyvinylsilane,  
triethylvinylsilane, vinyltrichlorosilane, vinyltrimethoxysilane, vinyltrimethylsilane, and  
mixtures thereof.

101: A method according to claim 99, wherein the silanized support is polymerized with an olefin containing monomer.

102. A method according to claim 101, wherein the olefin-containing monomer  
5 contains a functional group.

103. A method according to claim 102, wherein the olefin-containing monomer is selected from the group consisting of acrylic acid, methacrylic acid, vinylacetic acid, 4-vinylbenzoic acid, itaconic acid, allyl amine, allylethylamine, 4-aminostyrene, 2-  
10 aminoethyl methacrylate, acryloyl chloride, methacryloyl chloride, chlorostyrene, dichlorostyrene, 4-hydroxystyrene, hydroxymethylstyrene, vinylbenzyl alcohol, allyl alcohol, 2-hydroxyethyl methacrylate, poly(ethylene glycol) methacrylate, and mixtures thereof.

15 104. A method according to claim 101, wherein the support is polymerized with a monomer selected from the group consisting of acrylic acid, acrylamide, methacrylic acid, vinylacetic acid, 4-vinylbenzoic acid, itaconic acid, allyl amine, allylethylamine, 4-aminostyrene, 2-aminoethyl methacrylate, acryloyl chloride, methacryloyl chloride, chlorostyrene, dichlorostyrene, 4-hydroxystyrene, hydroxymethyl styrene, vinylbenzyl  
20 alcohol, allyl alcohol, 2-hydroxyethyl methacrylate, poly(ethylene glycol) methacrylate, and mixtures thereof, together with a monomer selected from the group consisting of acrylic acid, methacrylic acid, vinylacetic acid, 4-vinylbenzoic acid, itaconic acid, allyl amine, allylethylamine, 4-aminostyrene, 2-aminoethyl methacrylate, acryloyl chloride, methacryloyl chloride, chlorostyrene, dichlorostyrene, 4-hydroxystyrene, hydroxymethyl  
25 styrene, vinylbenzyl alcohol, allyl alcohol, 2-hydroxyethyl methacrylate, poly(ethylene glycol) methacrylate, methyl acrylate, methyl methacrylate, ethyl acrylate, ethyl methacrylate, styrene, 1-vinylimidazole, 2-vinylpyridine, 4-vinylpyridine, divinylbenzene, ethylene glycol dimethacrylate, *N,N'*-methylenediacrylamide, *N,N'*-phenylenediacrylamide, 3,5-bis(acryloylamido) benzoic acid, pentaerythritol triacrylate,  
30 trimethylolpropane trimethacrylate, pentaerythritol tetraacrylate, trimethylolpropane ethoxylate (14/3 EO/OH) triacrylate, trimethylolpropane ethoxylate (7/3 EO/OH) triacrylate, trimethylolpropane propoxylate (1 PO/OH) triacrylate, trimethylolpropane propoxylate (2 PO/OH) triacrylate, and mixtures thereof.

35 105. A method according to claim 99, wherein said forming comprises:  
photolithographically masking the solid support;  
photochemically deprotecting the linker or outermost nucleotides attached to the solid support at unmasked array positions; and  
adding nucleotides with a photoactivatable protecting group at  
40 photochemically deprotected array positions.

106. A method according to claim 105, wherein the photoactivable protecting group is selected from the group consisting of nitroveratryloxycarbonyl, o-nitrobenzyloxycarbonyl, fluorenylmethoxycarbonyl, dimethyl-dimethoxybenzyloxycarbonyl, oxymethyleneanthraquinone, and mixtures thereof.
- 5
107. A method according to claim 105, wherein the protecting group protects the nucleotides at their 3' or 5' ends.
108. A method according to claim 105 further comprising:  
10 washing the solid support after said photochemically deprotecting and said adding.
109. A method according to claim 89, wherein the surface or linker is non-hydrolyzable.
- 15
110. A method according to claim 89, wherein the solid support has an array of positions with the plurality of capture oligonucleotides having the same nucleotide sequences.
- 20
111. A method according to claim 93, wherein each capture oligonucleotide differs from its adjacent capture oligonucleotide on the array by at least 25% of the nucleotides.
- 25
112. A method according to claim 93, wherein each capture oligonucleotide is separated from adjacent capture oligonucleotides by barrier oligonucleotides which are shorter than the capture oligonucleotides.
- 30
113. A method according to claim 89, wherein said method is carried out with a device having a plurality of chambers having separate valves on separate connections to a source of the multimer nucleotides and to a source of vacuum, said method further comprising:
- 35
- orienting the device and the solid support for application of the multimer nucleotides to the solid support;
  - opening the valve to the source of vacuum to seal the chambers of the device against the solid support;
  - 40 closing the valve to the source of vacuum;
  - opening the valve to the source of multimer nucleotides to supply the multimer nucleotides to the chambers for the attaching of multimer nucleotides at the activated array positions; and
  - closing the valve to the source of multimer nucleotides after the attaching.

114. A method according to claim 113, wherein the device has the chambers separately along rows and columns of the array.

115. A method according to claim 113, wherein the device has the chambers  
5 along rows of the array.

116. A method according to claim 115, wherein the chambers are configured to deliver multimer nucleotides a precise column positions.

117. A method according to claim 115, wherein said forming comprises:  
applying a multimer nucleotide along parallel rows of the solid  
support;  
turning the support 90 degrees;  
attaching a multimer nucleotide along parallel rows of the solid support to  
15 form oligonucleotides at row intersections having 2 sets of multimer nucleotides by said  
opening the valve to the source of vacuum, said closing the valve to the source of vacuum,  
said opening the valve to the source of multimer nucleotides, and said closing the valve to  
the source of multimer nucleotides; and  
repeating said applying, turning, and attaching until the oligonucleotides  
20 are formed at the row intersections.

118. A method according to claim 113, wherein said device comprises a valve  
block assembly with plural input ports leading to sources of multimer nucleotides and  
plural output ports leading to chambers.  
25

119. A method according to claim 118, wherein the valve block assembly is  
cylindrical and has 2 adjacent rotatable portions which can be positioned relative to one  
another to connect selectively the input and output ports.

120. An array of oligonucleotides on a solid support comprising:  
a solid support having an array of positions each suitable for attachment of  
an oligonucleotide;  
a linker or support suitable for coupling an oligonucleotide to the solid  
support attached to the solid support at each of the array positions;  
35 and an array of oligonucleotides on the solid support with at least some of  
the array positions being occupied by oligonucleotides having greater than sixteen  
nucleotides.

121. An array according to claim 120, wherein different oligonucleotides are  
40 attached at different array positions on the solid support to detect different nucleic acids.

122. An array according to claim 120, wherein the solid support is made from a material selected from the group consisting of plastic, ceramic, metal, resin, gel, glass, silicon, and composites thereof.

5 123. An array according to claim 120, wherein the solid support is in a form selected from the group consisting of slides, discs, membranes, films, and composites thereof.

124. An array according to claim 120, wherein the solid support has an array of  
10 positions with oligonucleotides attached to the array of positions.

125. An array according to claim 124, wherein the solid support has wells, raised regions, or etched trenches.

15 126. An array according to claim 125, wherein the solid support is in a microtiter plate.

127. An array according to claim 120, wherein the linker comprises a silane on a  
20 surface of the solid support.

128. An array according to claim 120, wherein the solid support is functionalized with olefin, amino, hydroxyl, silanol, aldehyde, keto, halo, acyl halide, or carboxyl groups.

25 129. An array according to claim 128, wherein the solid support is functionalized with an amino group by reaction with an amine compound selected from the group consisting of 3-aminopropyl triethoxysilane, 3-aminopropylmethyldiethoxysilane, 3-aminopropyl dimethylethoxysilane, 3-aminopropyl trimethoxysilane, N-(2-aminoethyl)-3-aminopropylmethyl dimethoxysilane, N-(2-  
30 aminoethyl-3-aminopropyl) trimethoxysilane, aminophenyl trimethoxysilane, 4-aminobutyldimethyl methoxysilane, 4-aminobutyl triethoxysilane, aminoethylaminomethylphenethyl trimethoxysilane, and mixtures thereof.

130. An array according to claim 128, wherein the solid support is  
35 functionalized with an olefin-containing silane.

131. An array according to claim 130, wherein the olefin-containing silane is selected from the group consisting of 3-(trimethoxysilyl)propyl methacrylate, N-[3-(trimethoxysilyl)propyl]-N'-(4-vinylbenzyl)ethylenediamine, triethoxyvinylsilane,

triethylvinylsilane, vinyltrichlorosilane, vinyltrimethoxysilane, vinyltrimethylsilane, and mixtures thereof.

132. An array according to claim 130, wherein the silanized support is  
5 polymerized with an olefin containing monomer.

133. An array according to claim 132, wherein the olefin-containing monomer  
contains a functional group.

10 134. An array according to claim 133, wherein the olefin-containing monomer is  
selected from the group consisting of acrylic acid, methacrylic acid, vinylacetic acid, 4-  
vinylbenzoic acid, itaconic acid, allyl amine, allylethylamine, 4-aminostyrene, 2-  
aminoethyl methacrylate, acryloyl chloride, methacryloyl chloride, chlorostyrene,  
dichlorostyrene, 4-hydroxystyrene, hydroxymethylstyrene, vinylbenzyl alcohol, allyl  
15 alcohol, 2-hydroxyethyl methacrylate, poly(ethylene glycol) methacrylate, and mixtures  
thereof.

135. An array according to claim 132, wherein the support is polymerized with a  
monomer selected from the group consisting of acrylic acid, acrylamide, methacrylic acid,  
20 vinylacetic acid, 4-vinylbenzoic acid, itaconic acid, allyl amine, allylethylamine, 4-  
aminostyrene, 2-aminoethyl methacrylate, acryloyl chloride, methacryloyl chloride,  
chlorostyrene, dichlorostyrene, 4-hydroxystyrene, hydroxymethyl styrene, vinylbenzyl  
alcohol, allyl alcohol, 2-hydroxyethyl methacrylate, poly(ethylene glycol) methacrylate,  
and mixtures thereof, together with a monomer selected from the group consisting of  
25 acrylic acid, methacrylic acid, vinylacetic acid, 4-vinylbenzoic acid, itaconic acid, allyl  
amine, allylethylamine, 4-aminostyrene, 2-aminoethyl methacrylate, acryloyl chloride,  
methacryloyl chloride, chlorostyrene, dichlorostyrene, 4-hydroxystyrene, hydroxymethyl  
styrene, vinylbenzyl alcohol, allyl alcohol, 2-hydroxyethyl methacrylate, poly(ethylene  
glycol) methacrylate, methyl acrylate, methyl methacrylate, ethyl acrylate, ethyl  
30 methacrylate, styrene, 1-vinylimidazole, 2-vinylpyridine, 4-vinylpyridine, divinylbenzene,  
ethylene glycol dimethacrylate, *N,N*-methylenediacrylamide, *N,N*-  
phenylenediacrylamide, 3,5-bis(acryloylamido) benzoic acid, pentaerythritol triacrylate,  
trimethylolpropane trimethacrylate, pentaerythritol tetraacrylate, trimethylolpropane  
ethoxylate (14/3 EO/OH) triacrylate, trimethylolpropane ethoxylate (7/3 EO/OH)  
35 triacrylate, trimethylolpropane propoxylate (1 PO/OH) triacrylate, trimethylolpropane  
propoxylate (2 PO/OH) triacrylate, and mixtures thereof.

136. An array according to claim 120, wherein the linker or support is non-  
hydrolyzable.

137. An array according to claim 120, wherein the array is reusable for repeatedly hybridizing oligonucleotides to the array of oligonucleotides on the solid support.

5 138. A kit for identifying one or more of a plurality of sequences differing by single-base changes, insertions, deletions, or translocations in a plurality of target nucleotide sequences comprising:

- a ligase;
- a plurality oligonucleotide probe sets, each characterized by (a) a first
- 10 oligonucleotide probe, having a target sequence-specific portion and an addressable array-specific portion, and (b) a second oligonucleotide probe, having a target sequence-specific portion and detectable reporter label, wherein the oligonucleotide probes in a particular set are suitable for ligation together when hybridized adjacent to one another on a respective target nucleotide sequence, but have a mismatch which interferes with such ligation when
- 15 hybridized to any other nucleotide sequence, present in the sample; and
  - a solid support with capture oligonucleotides immobilized at particular sites, wherein the capture oligonucleotides have nucleotide sequences complementary to the addressable array-specific portions.

20 139. A kit according to claim 138, wherein the mismatch of oligonucleotide probe sets to nucleotide sequences other than their respective target nucleotide sequences is at a base at a ligation junction at which the oligonucleotide probe of each set ligate together when hybridized to their respective target nucleotide sequences.

25 140. A kit according to claim 138, wherein the mismatch is on the oligonucleotide probe of the oligonucleotide probe sets which have 3' ends at the ligation junction.

30 141. A kit according to claim 138, wherein the mismatch of oligonucleotide probe sets to nucleotide sequences other than their respective target nucleotide sequence is at a base adjacent to a ligation junction at which the oligonucleotide probes of each set ligate together when hybridized to their respective target nucleotide sequences.

35 142. A kit according to claim 141, wherein the mismatch is on the oligonucleotide probe of the oligonucleotide probe sets which have 3' ends at the ligation junction.

143. A kit according to claim 138, wherein the ligase is selected from the group consisting of *Thermus aquaticus* ligase, *Thermus thermophilus* ligase, *E. coli* ligase, T4 ligase, and *Pyrococcus* ligase.

144. A kit according to claim 138 further comprising:  
amplification primers suitable for preliminary amplification of the target  
nucleotide sequences and  
a polymerase.

5

145. A kit according to claim 138, wherein the solid support includes different  
capture oligonucleotides immobilized at different particular sites with different capture  
oligonucleotides being complementary to different addressable array-specific portions,  
whereby different oligonucleotide probe sets are hybridized and detected at different sites  
on the solid support.

10

146. A kit according to claim 138, wherein the solid support includes identical  
capture oligonucleotides immobilized on the solid support with the capture  
oligonucleotides complementary to all the addressable array-specific portions and the  
labels attached to the oligonucleotide probe sets being different, whereby the  
oligonucleotide probe sets are detected and distinguished by the different labels.

15

147. A kit according to claim 138, wherein the oligonucleotide probe sets and  
the capture oligonucleotides are configured so that the oligonucleotide probe sets  
hybridize, respectively, to the target nucleotide sequences at temperatures which are less  
than that at which the capture oligonucleotides hybridize to the addressable array-specific  
portions of the oligonucleotide probes sets.

20



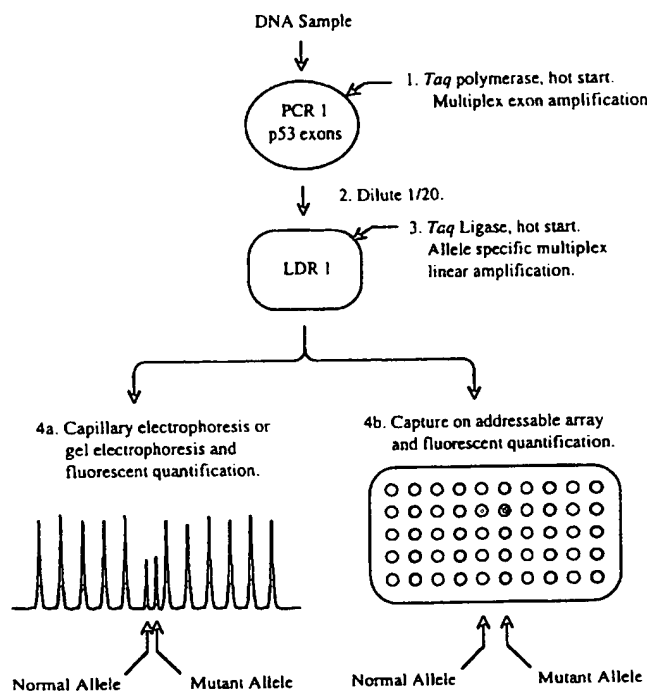


FIG. 1

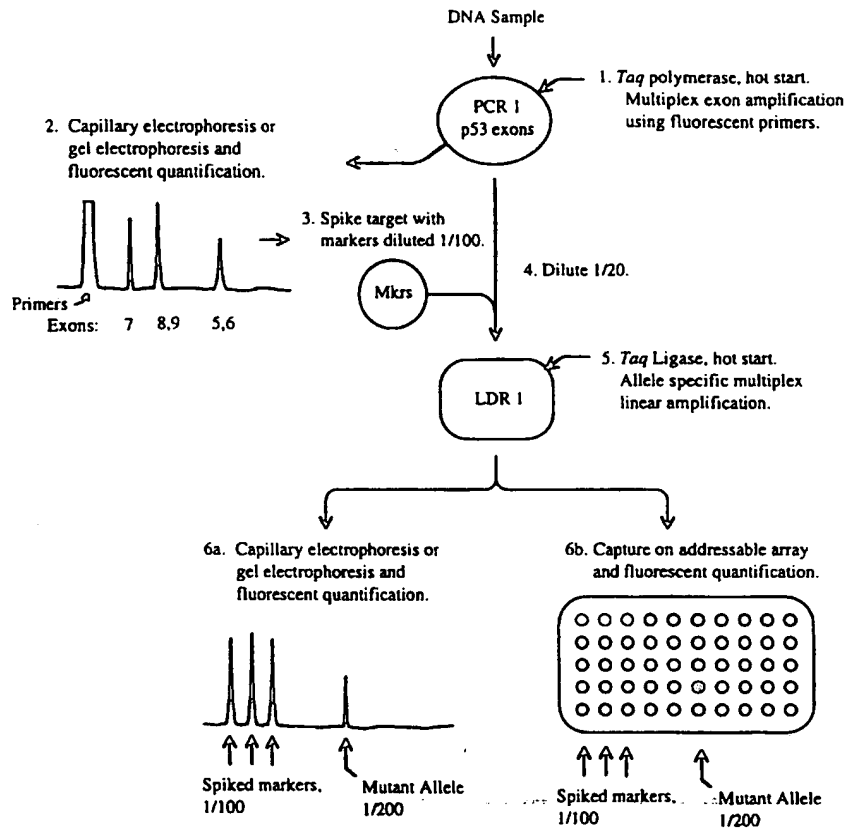
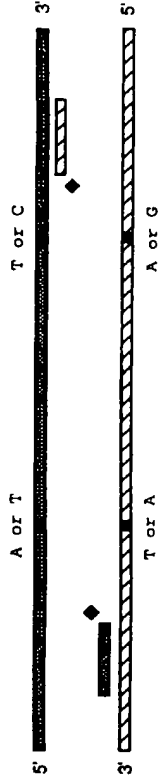


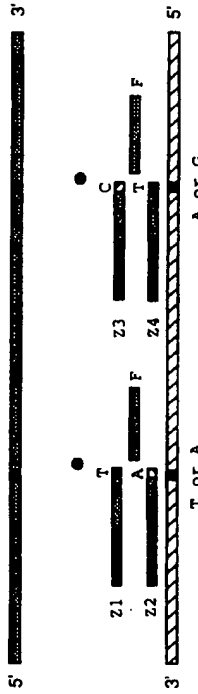
FIG. 2

**PCR/LDR**

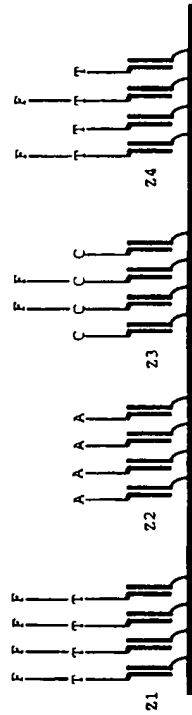
1. PCR amplify region(s) containing mutations using primers, dNTPs and Taq polymerase. ◆



2. Perform LDR using allele-specific LDR primers and thermostable ligase. ●  
 Allele specific oligonucleotides ligate to common oligonucleotides only when there is perfect complementarity at the junction.



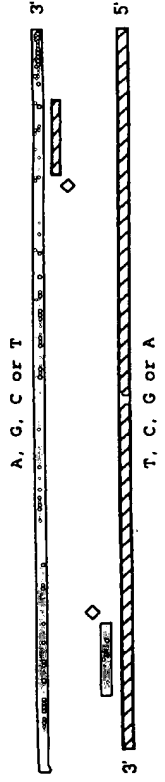
3. Capture fluorescent products on addressable array and quantify each allele.



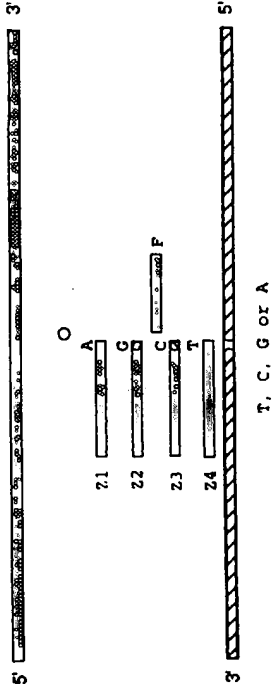
Homozygous: T allele only. Heterozygous: C and T alleles.

**FIG. 3**

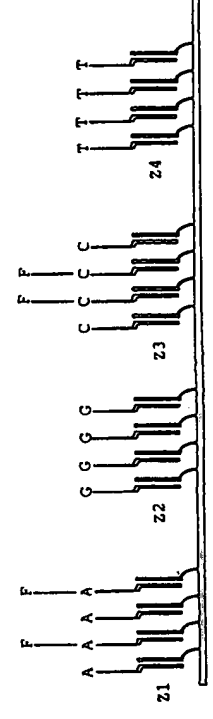
**PCR/LDR**



1. PCR amplify region(s) containing mutations using primers, dNTPs and Taq polymerase. ◊



2. Perform LDR using allele-specific LDR primers and thermostable ligase. ◊  
 Allele specific oligonucleotides ligate to common oligonucleotides only when there is perfect complementarity at the junction.



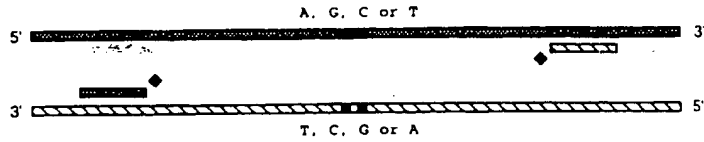
3. Capture fluorescent products on addressable array and quantify each allele.

Heterozygous: A and C alleles.

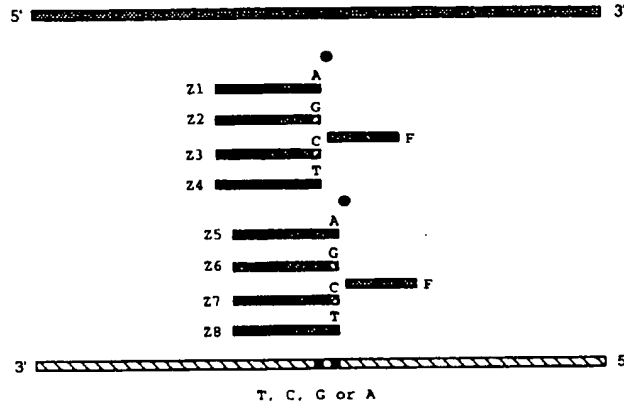
**FIG. 4**

**PCR/ LDR : Nearby alleles**

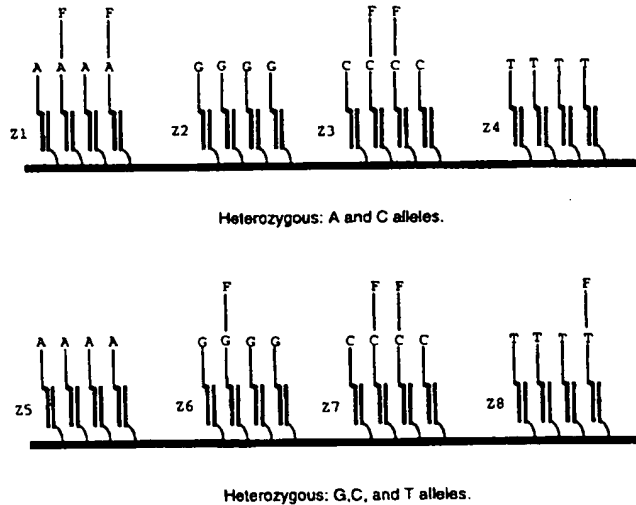
1. PCR amplify region(s) containing mutations using primers, dNTPs and Taq polymerase. ◆



2. Perform LDR using allele-specific LDR primers and thermostable ligase. ●  
 Allele specific oligonucleotides ligate to common oligonucleotides only when there is perfect complementarity at the junction.



3. Capture fluorescent products on addressable array and quantify each allele.



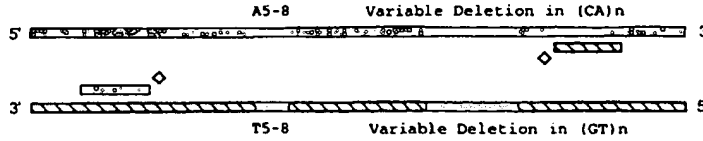
**FIG. 5**

SUBSTITUTE SHEET (RULE 26)

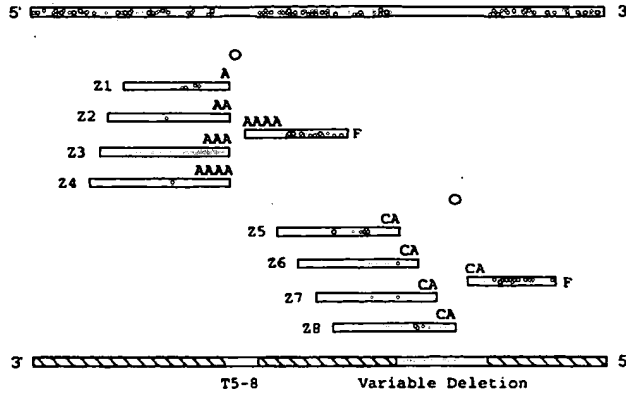
6/34

**PCR/ LDR : Insertions and Deletions**

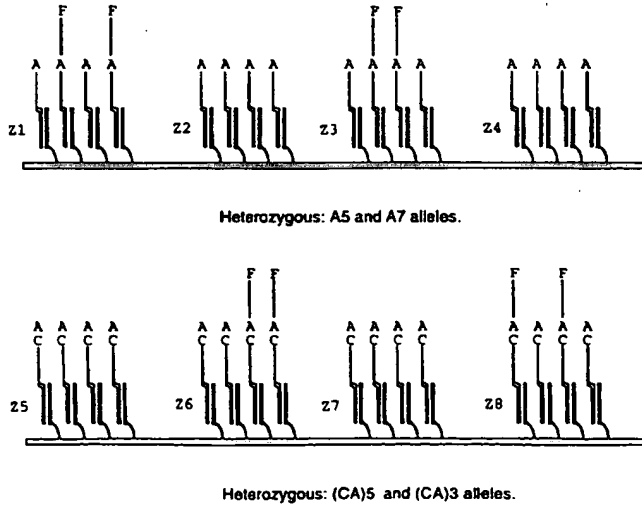
1. PCR amplify region(s) containing mutations using primers, dNTPs and *Taq* polymerase.



2. Perform LDR using allele-specific LDR primers and thermostable ligase. Allele specific oligonucleotides ligate to common oligonucleotides only when there is perfect complementarity at the junction.



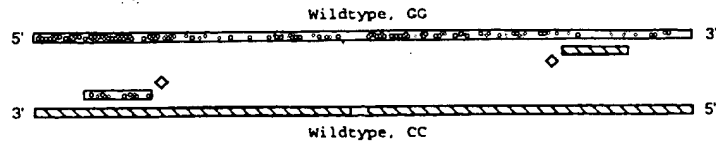
3. Capture fluorescent products on addressable array and quantify each allele.



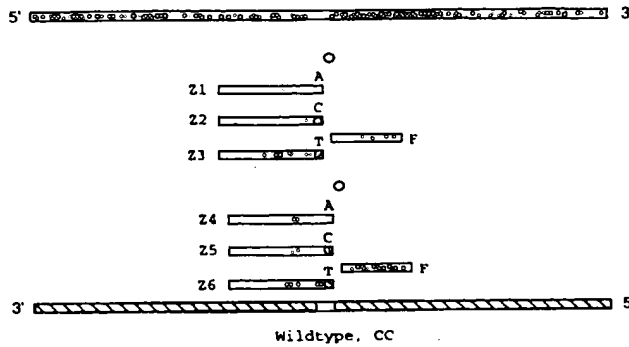
**FIG. 6**  
SUBSTITUTE SHEET (RULE 26)

**PCR/ LDR : Adjacent alleles, cancer detection**

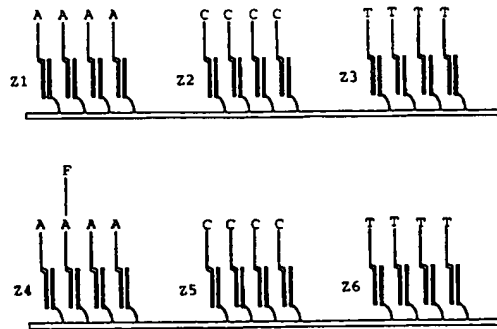
1. PCR amplify region(s) containing mutations using primers, dNTPs and *Taq* polymerase.



2. Perform LDR using allele-specific LDR primers and thermostable ligase. Allele specific oligonucleotides ligate to common oligonucleotides only when there is perfect complementarity at the junction.



3. Capture fluorescent products on addressable array and quantify each allele.



Gly to Asp mutation

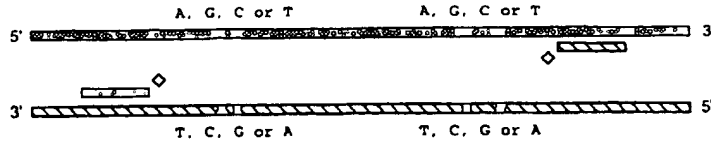
**FIG. 7**

SUBSTITUTE SHEET (RULE 26)

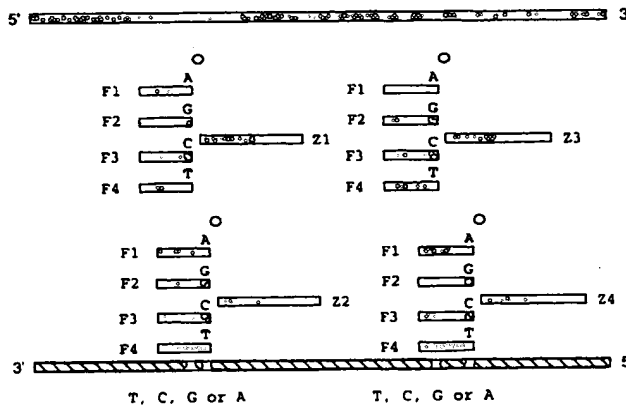
8/34

**PCR/ LDR : Nearby alleles**

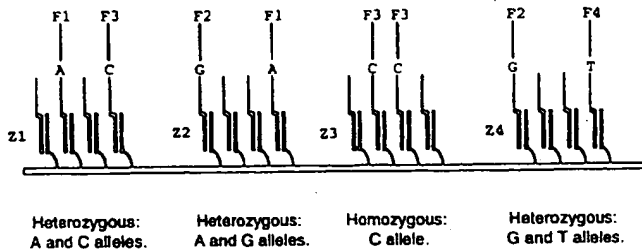
1. PCR amplify region(s) containing mutations using primers, dNTPs and Taq polymerase. ◊



2. Perform LDR using allele-specific LDR primers and thermostable ligase. ○  
 Allele specific oligonucleotides ligate to common oligonucleotides only when there is perfect complementarity at the junction.



3. Capture fluorescent products on addressable array and quantify each allele.



**FIG. 8**

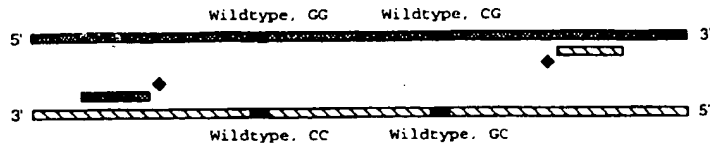
SUBSTITUTE SHEET (RULE 26)



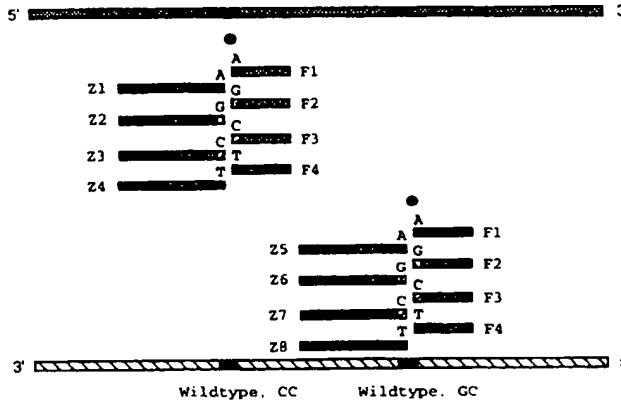
9/34

**PCR/ LDR : Adjacent and Nearby alleles**

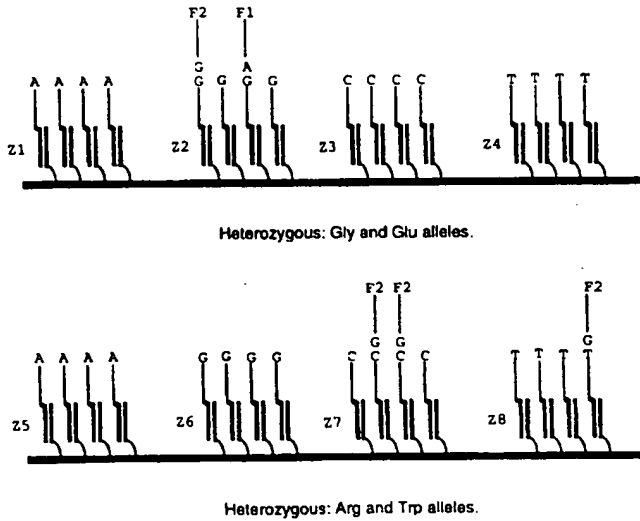
1. PCR amplify region(s) containing mutations using primers, dNTPs and *Taq* polymerase. ◆



2. Perform LDR using allele-specific LDR primers and thermostable ligase. ●  
 Allele specific oligonucleotides ligate to common oligonucleotides only when there is perfect complementarity at the junction.



3. Capture fluorescent products on addressable array and quantify each allele.

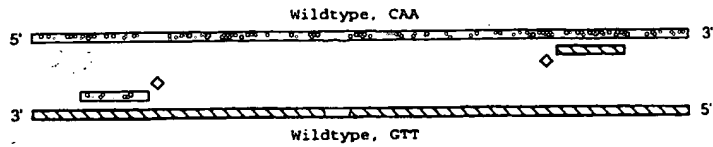


**FIG. 9**

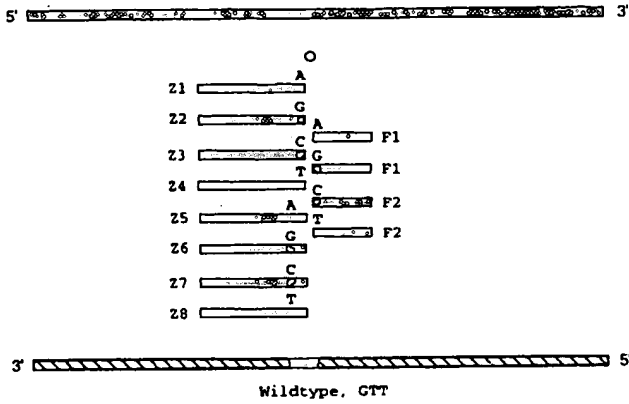
10/34

**PCR/ LDR : All alleles of a single codon**

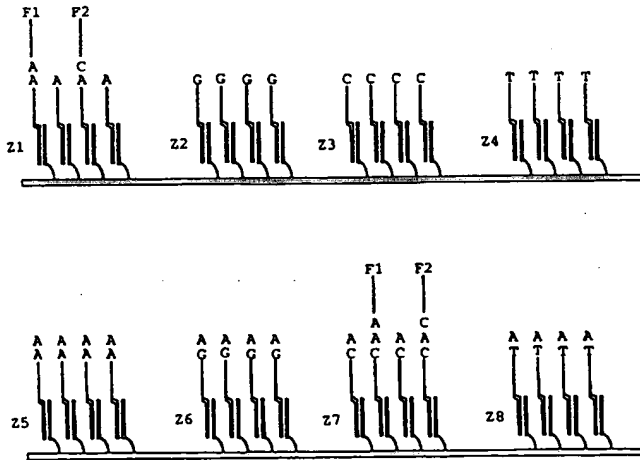
1. PCR amplify region(s) containing mutations using primers, dNTPs and Taq polymerase. ◊



2. Perform LDR using allele-specific LDR primers and thermostable ligase. ◊  
Allele specific oligonucleotides ligate to common oligonucleotides only when there is perfect complementarity at the junction.



3. Capture fluorescent products on addressable array and quantify each allele.

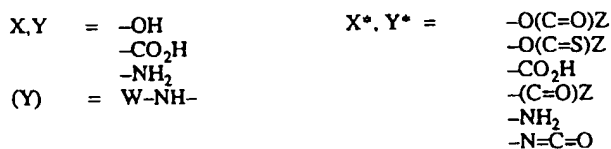
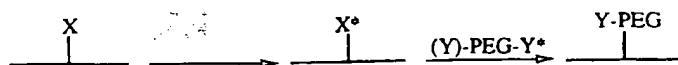


Heterozygous: Gln and His alleles.

**FIG. 10**

SUBSTITUTE SHEET (RULE 26)

11/34



W = protecting group, e.g. Boc, Fmoc

Z = activating group, e.g. imidazole (Im), *p*-nitrophenol (OPnp), hydroxysuccinimide (OSu), pentafluorophenol (OPfp)PEG = oligo or poly(ethylene glycol), backbone  $(\text{CH}_2\text{CH}_2\text{O})_n$   $n = 6$  to 200  
(can also be grown by anionic polymerization with  $\nabla_{\text{O}}$ )

WSC = water soluble carbodiimide

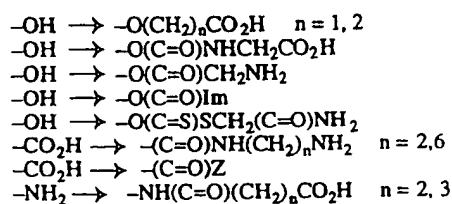
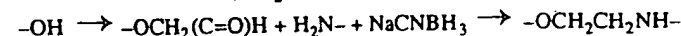
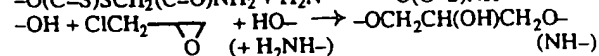
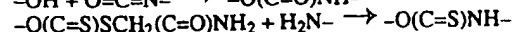
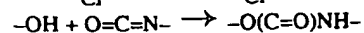
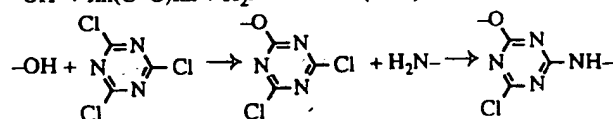
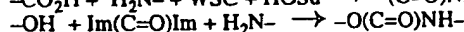
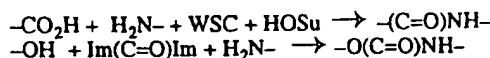
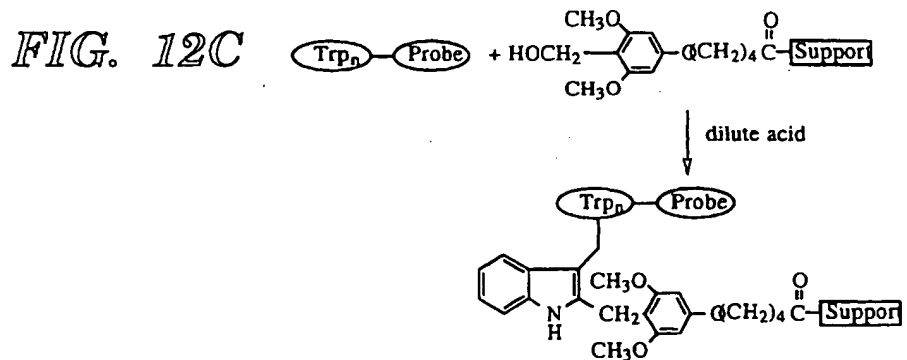
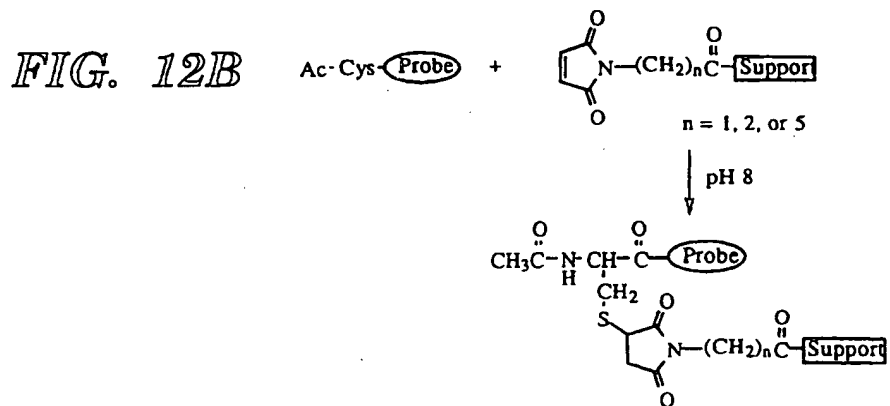
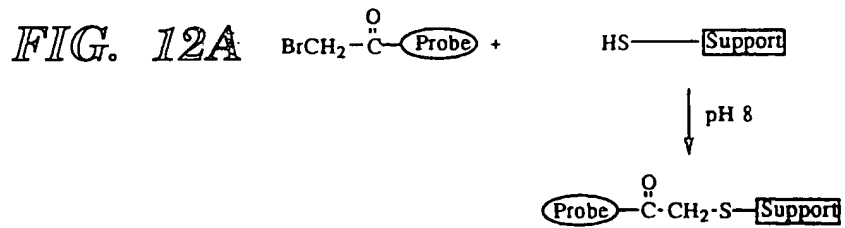
Functional group transformations/activation (as needed),  $\text{X} \rightarrow \text{X}^*$ ,  $\text{Y} \rightarrow \text{Y}^*$ Covalent linkage,  $\text{X}^* + \text{Y}^*$ 

FIG. 11

SUBSTITUTE SHEET (RULE 26)

12/34



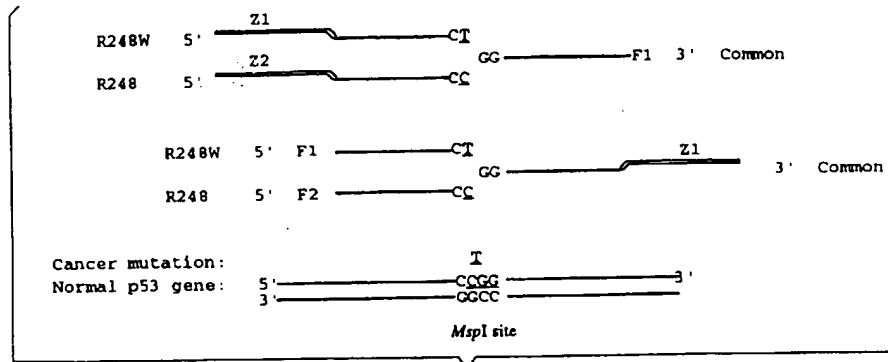


FIG. 13A

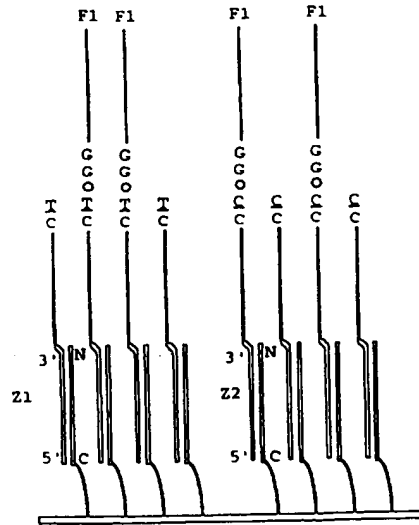


FIG. 13B

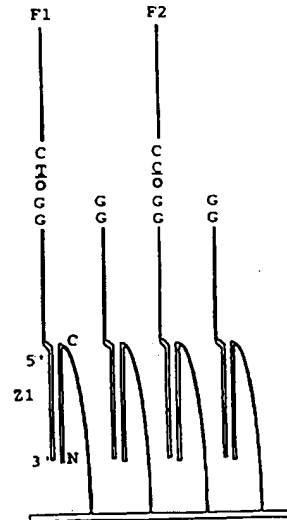


FIG. 13C

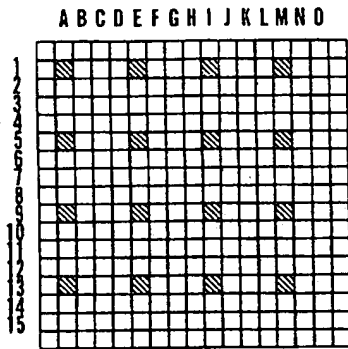


FIG. 14A

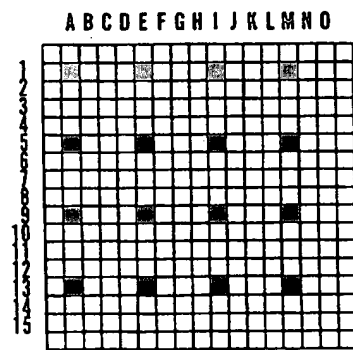


FIG. 14B

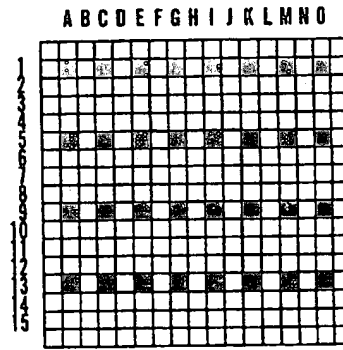


FIG. 14C

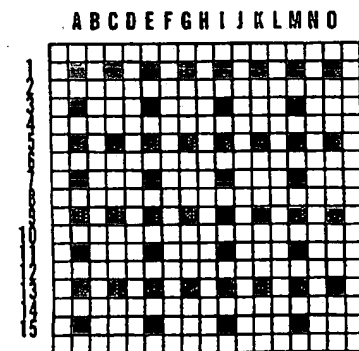


FIG. 14D

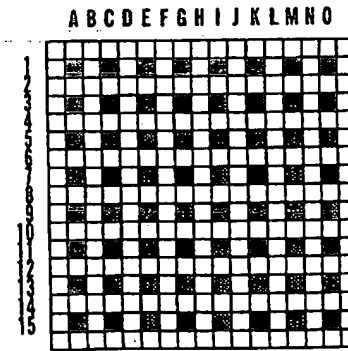
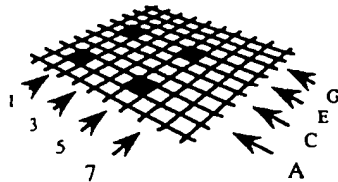


FIG. 14E

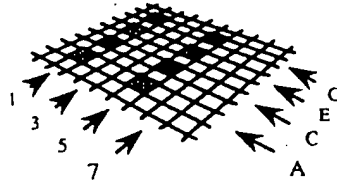
**FIG. 15A**

1st addition of unique 24mers.



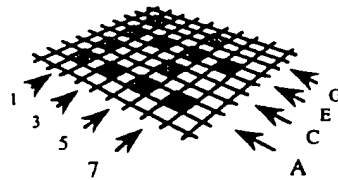
**FIG. 15B**

2nd addition of unique 24mers.



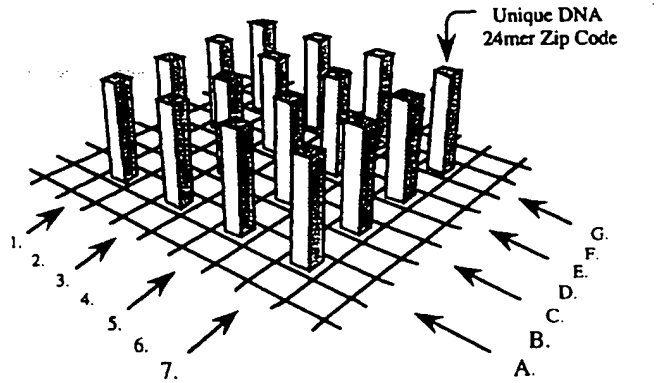
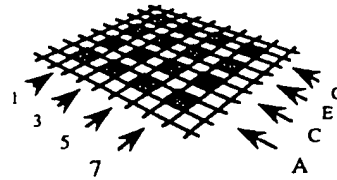
**FIG. 15C**

3rd addition of unique 24mers.



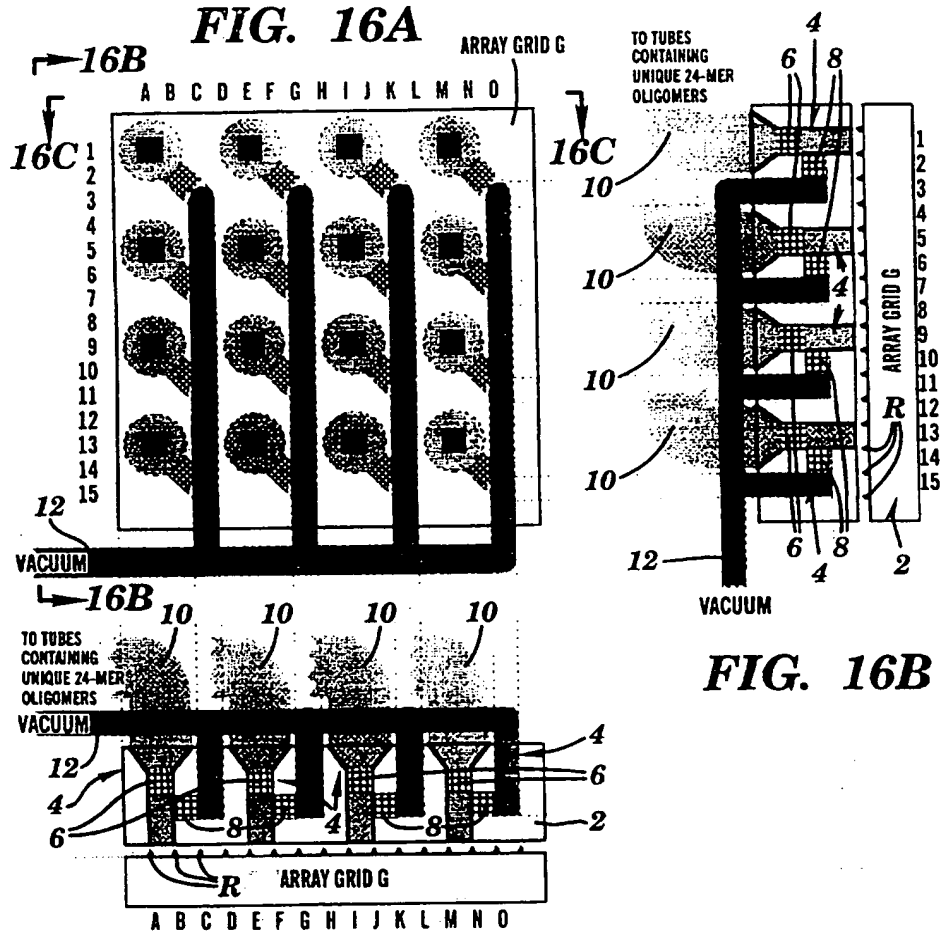
**FIG. 15D**

4th addition of unique 24mers.



**FIG. 15E**

SUBSTITUTE SHEET (RULE 26)



**FIG. 16C**



17/34

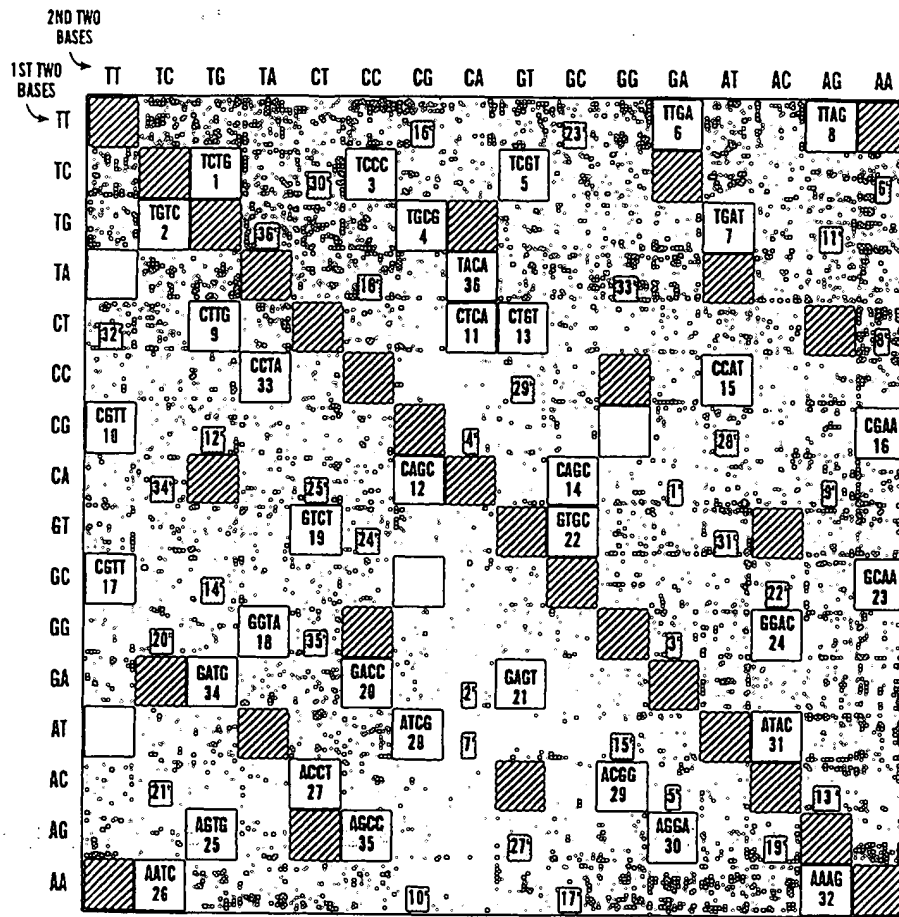


FIG. 17

SUBSTITUTE SHEET (RULE 26)

18/34

1st Tetramer addition  
(columns)

1	2	3	4	5
1	2	3	4	5
1	2	3	4	5
1	2	3	4	5
1	2	3	4	5

FIG. 18A

2nd Tetramer addition  
(rows)

6	6	6	6	6
5	5	5	5	5
4	4	4	4	4
3	3	3	3	3
2	2	2	2	2

FIG. 18B

3rd Tetramer addition  
(columns)

3	4	5	6	1
3	4	5	6	1
3	4	5	6	1
3	4	5	6	1
3	4	5	6	1

FIG. 18C

4th Tetramer addition  
(rows)

2	2	2	2	2
1	1	1	1	1
6	6	6	6	6
5	5	5	5	5
4	4	4	4	4

FIG. 18D

5th Tetramer addition  
(columns)

6	1	2	3	4
6	1	2	3	4
6	1	2	3	4
6	1	2	3	4
6	1	2	3	4

FIG. 18E

6th Tetramer addition  
(rows)

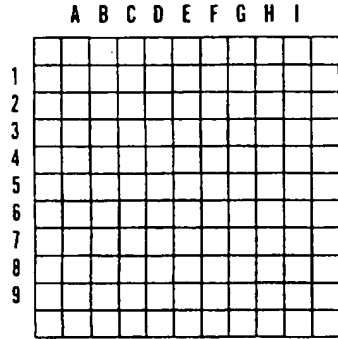
3	3	3	3	3
2	2	2	2	2
1	1	1	1	1
6	6	6	6	6
5	5	5	5	5

FIG. 18F

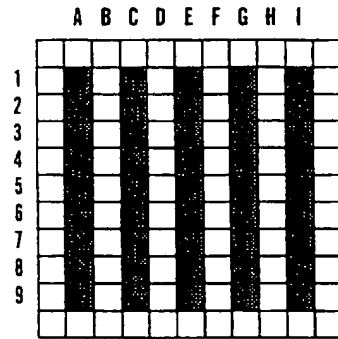
Addressable array with full length PNA 24mers

1-6-3-2-6-3	2-6-4-2-1-3	3-6-5-2-2-3	4-6-6-2-3-3	5-6-1-2-4-3
1-5-3-1-6-2	2-5-4-1-1-2	3-5-5-1-2-2	4-5-6-1-3-2	5-5-1-1-4-2
1-4-3-6-6-1	2-4-4-6-1-1	3-4-5-6-2-1	4-4-6-6-3-1	5-4-1-6-4-1
1-3-3-5-6-6	2-3-4-5-1-6	3-3-5-5-2-6	4-3-6-5-3-6	5-3-1-5-4-6
1-2-3-4-6-5	2-2-4-4-1-5	3-2-5-4-2-5	4-2-6-4-3-5	5-2-1-4-4-5

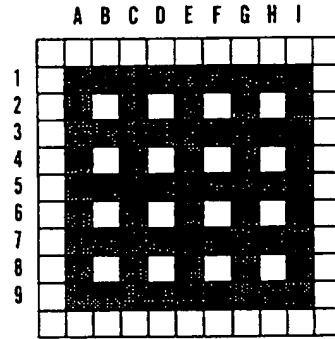
FIG. 18G



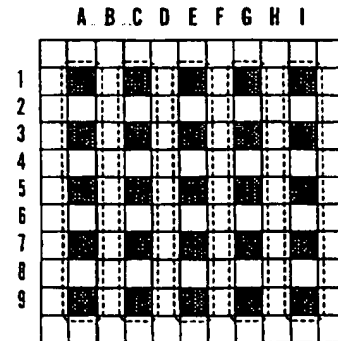
**FIG. 19A**



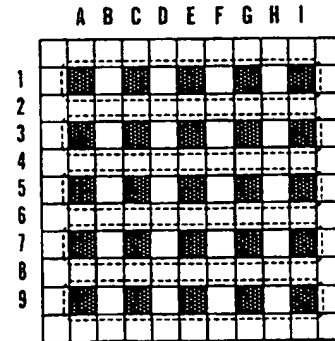
**FIG. 19B**



**FIG. 19C**



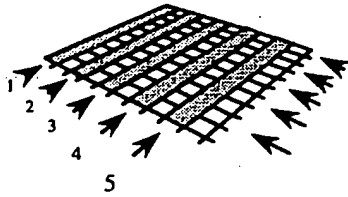
**FIG. 19D**



**FIG. 19E**

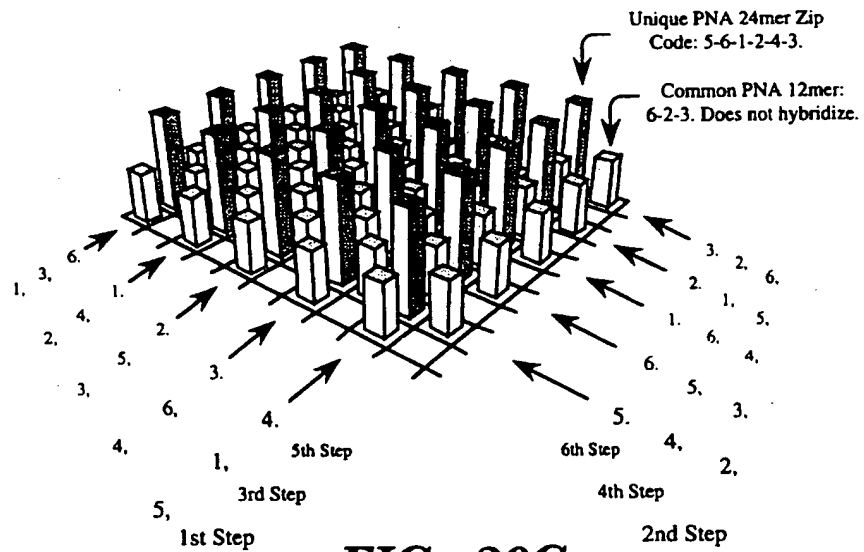
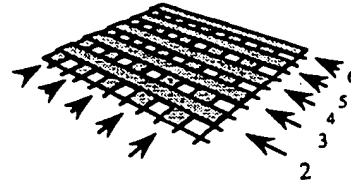
**FIG. 20A**

1st Tetramer additions  
(columns)

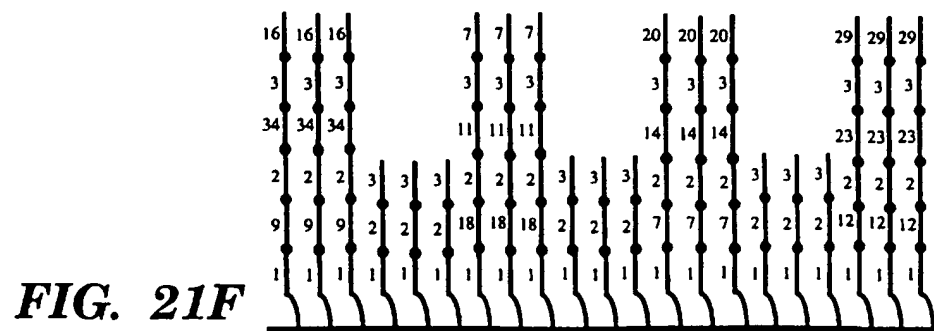
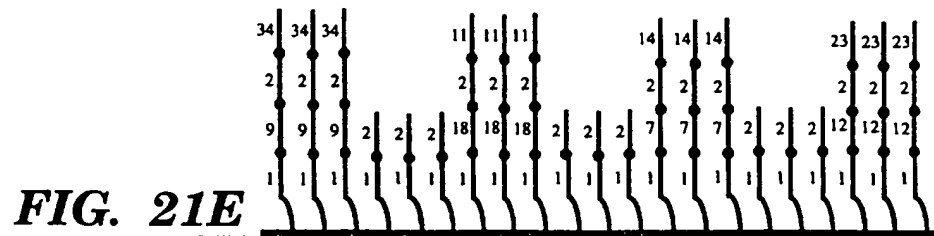
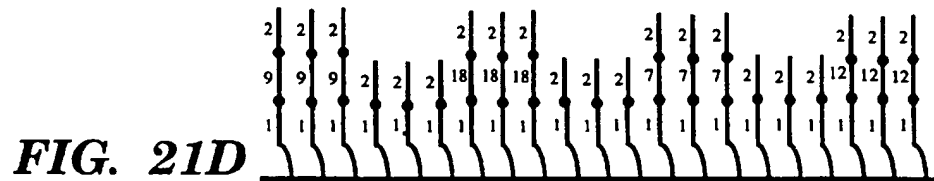
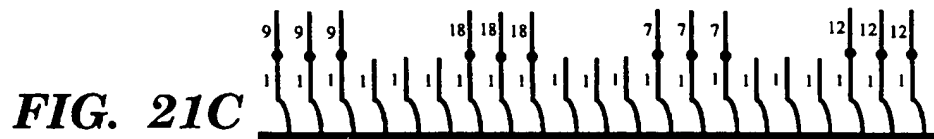


**FIG. 20B**

2nd Tetramer additions  
(rows)



**FIG. 20C**



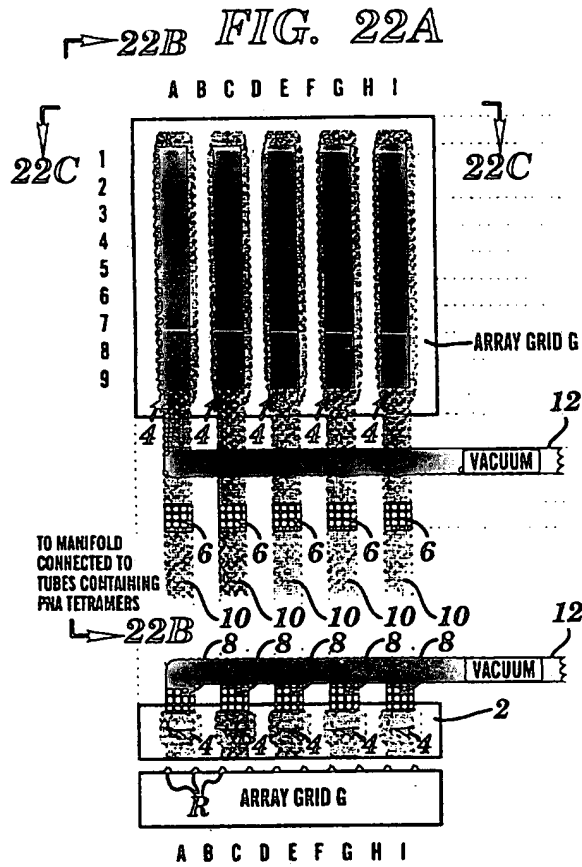


FIG. 22C

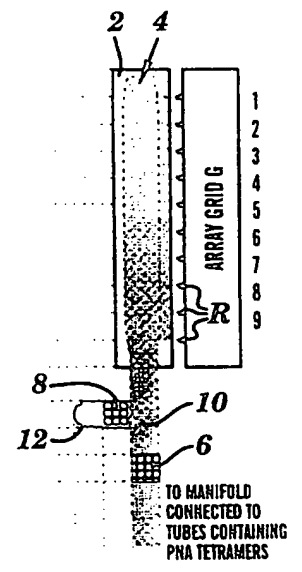
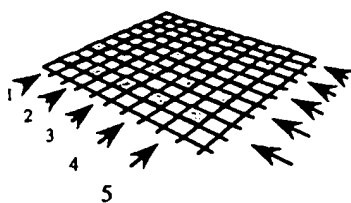


FIG. 22B

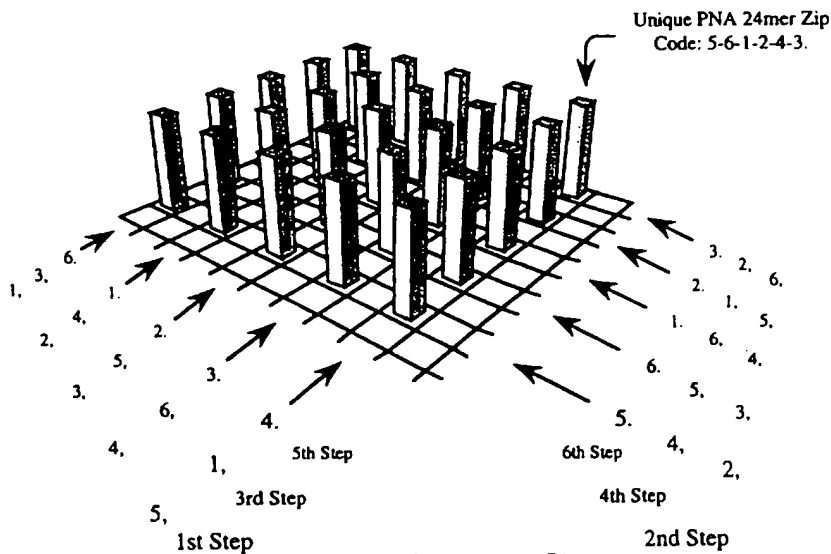
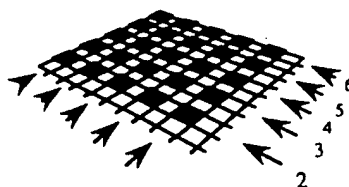
**FIG. 23A**

1st Tetramer additions  
(columns)



**FIG. 23B**

2nd Tetramer additions  
(rows)



**FIG. 23C**

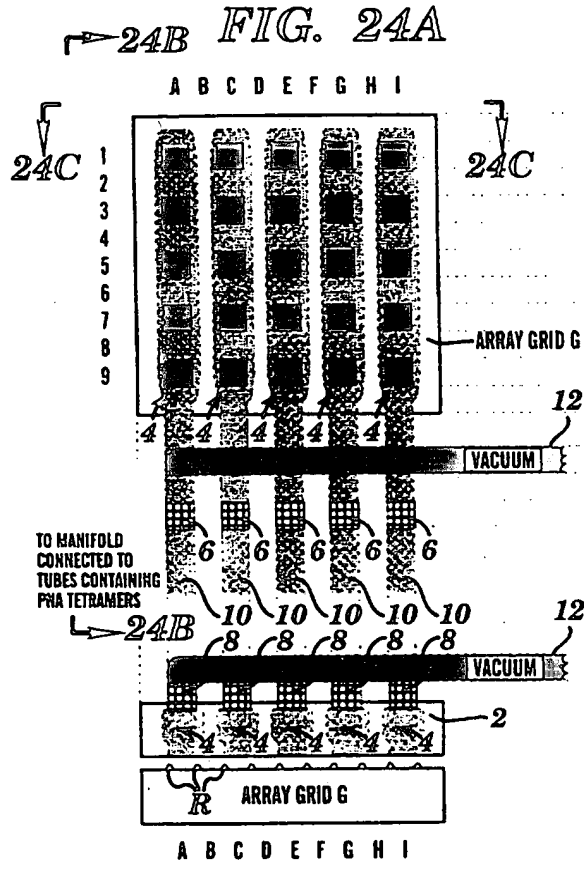


FIG. 24C

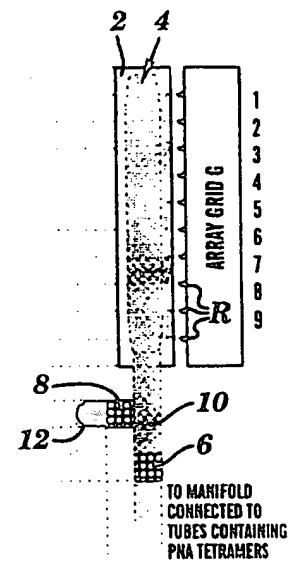


FIG. 24B



25/34

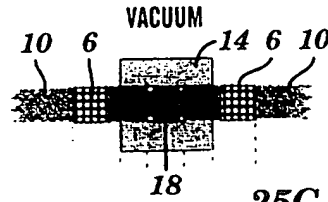


FIG. 25B

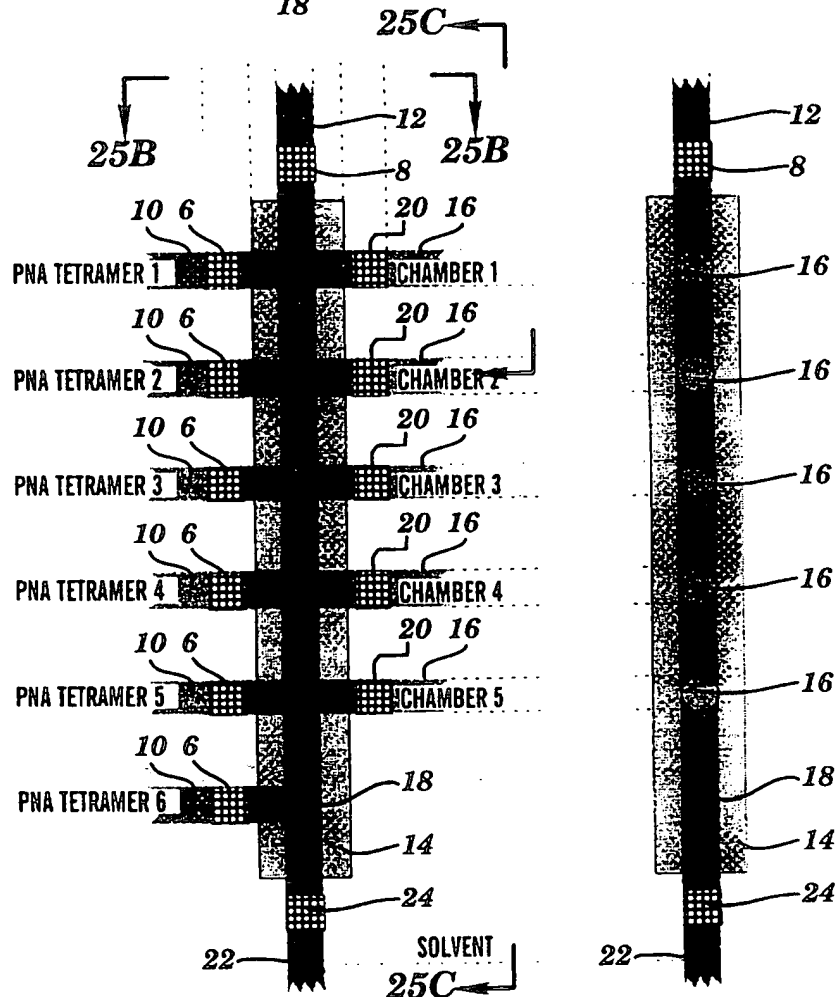


FIG. 25A

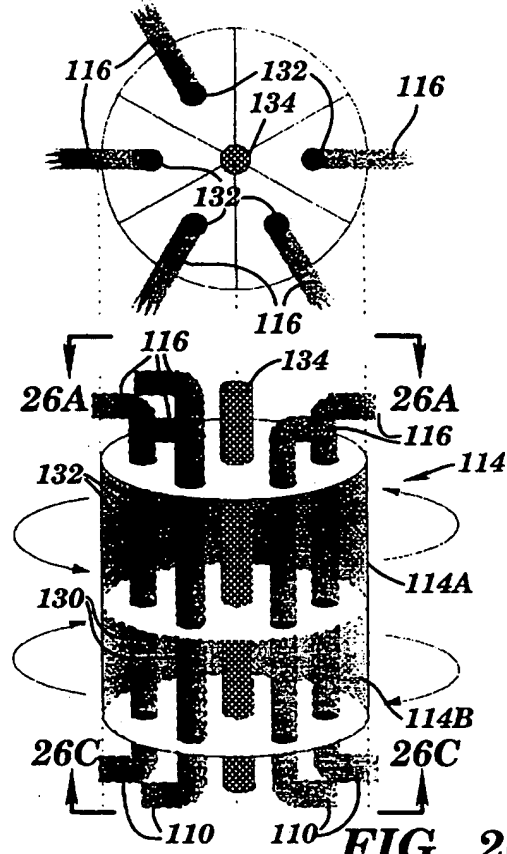
VALVE BLOCK ASSEMBLY

FIG. 25C

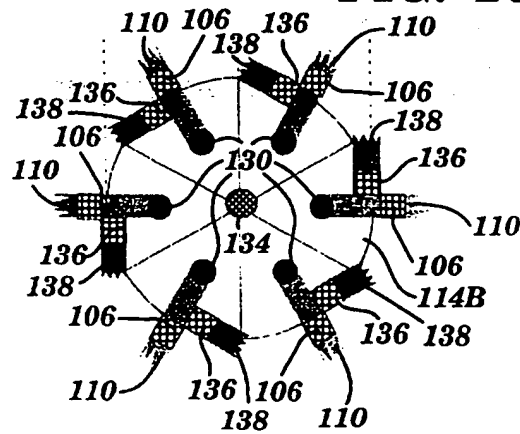
6 INPUTS AND 5 OUTPUTS

SUBSTITUTE SHEET (RULE 26)

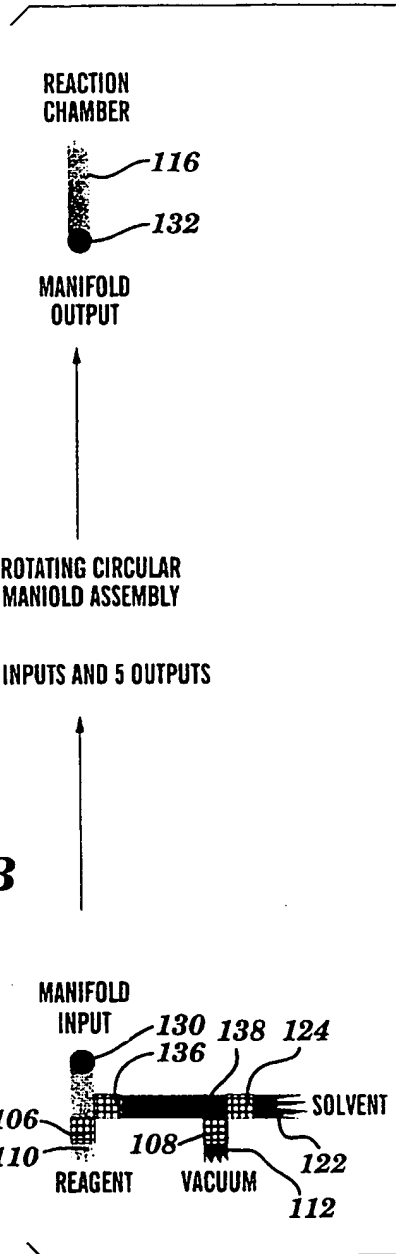
**FIG. 26A** 26/34



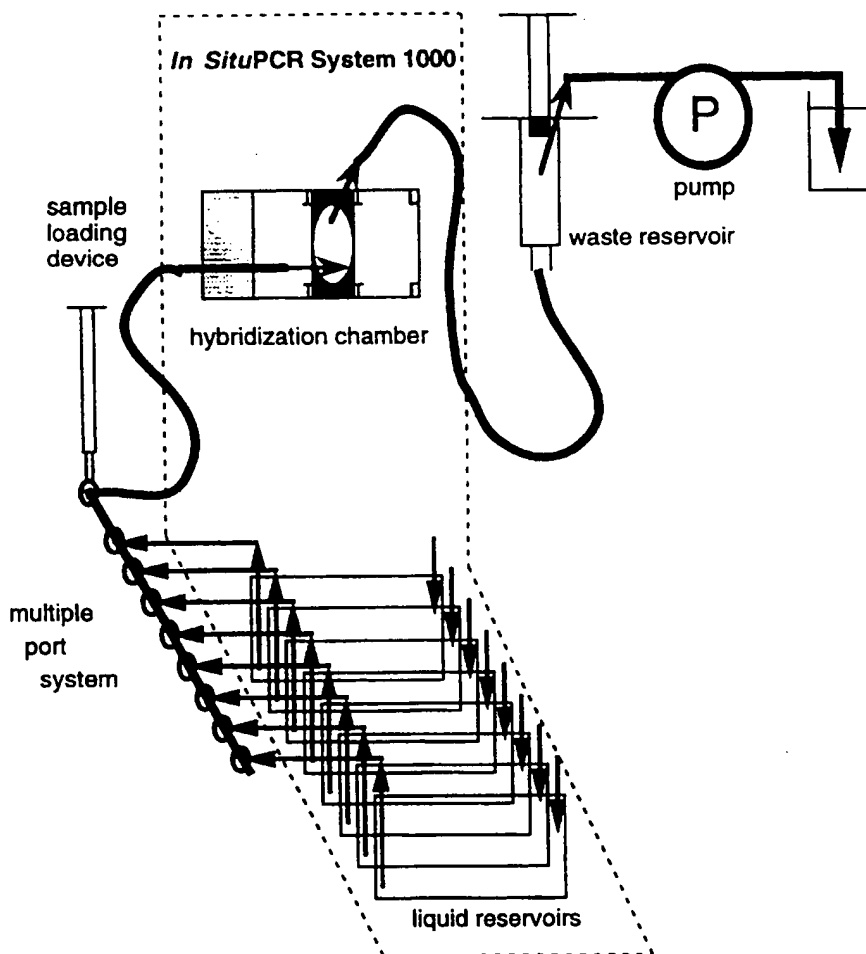
**FIG. 26B**



**FIG. 26C**

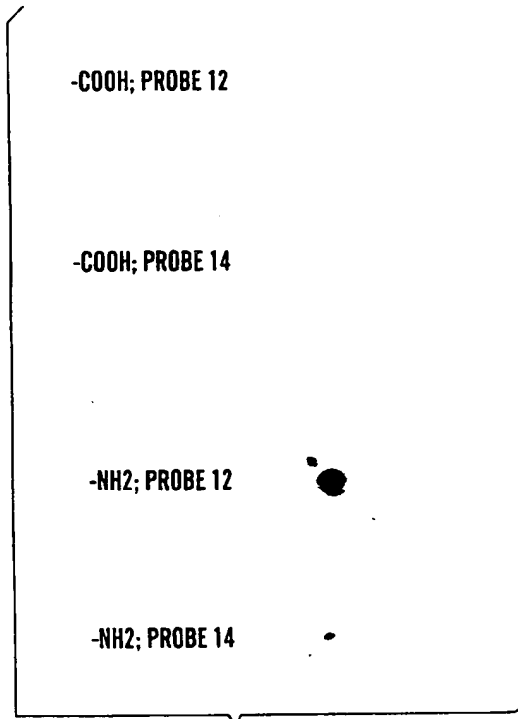


**FIG. 26D**



**FIG. 27**

28/34



**FIG. 28**

29/34

2% EGDMA      °  
                 °

2% HDDMA      °  
                 °

4% EGDMA      °  
                 °

*FIG. 29*

30/34



***FIG. 30***

31/34

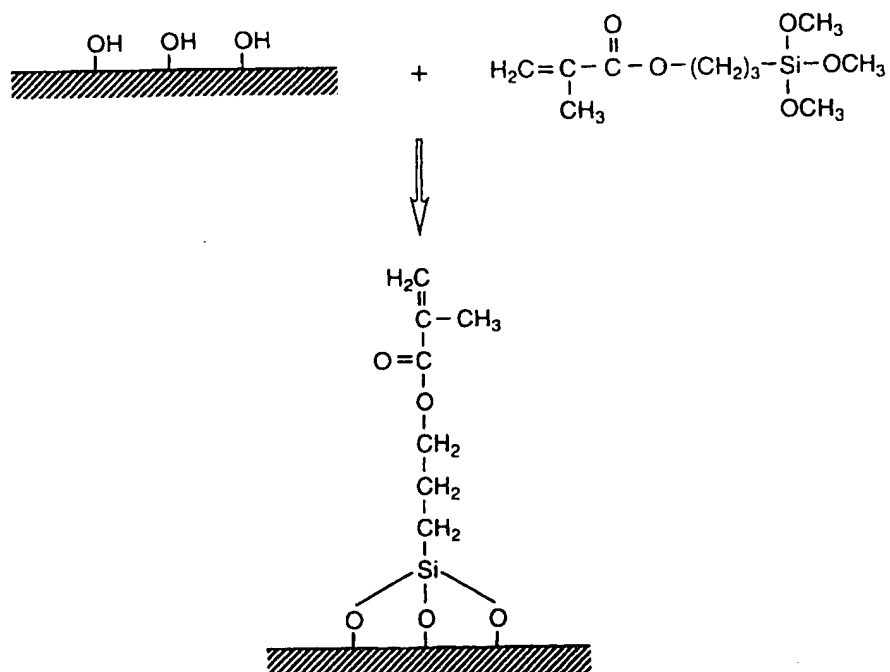
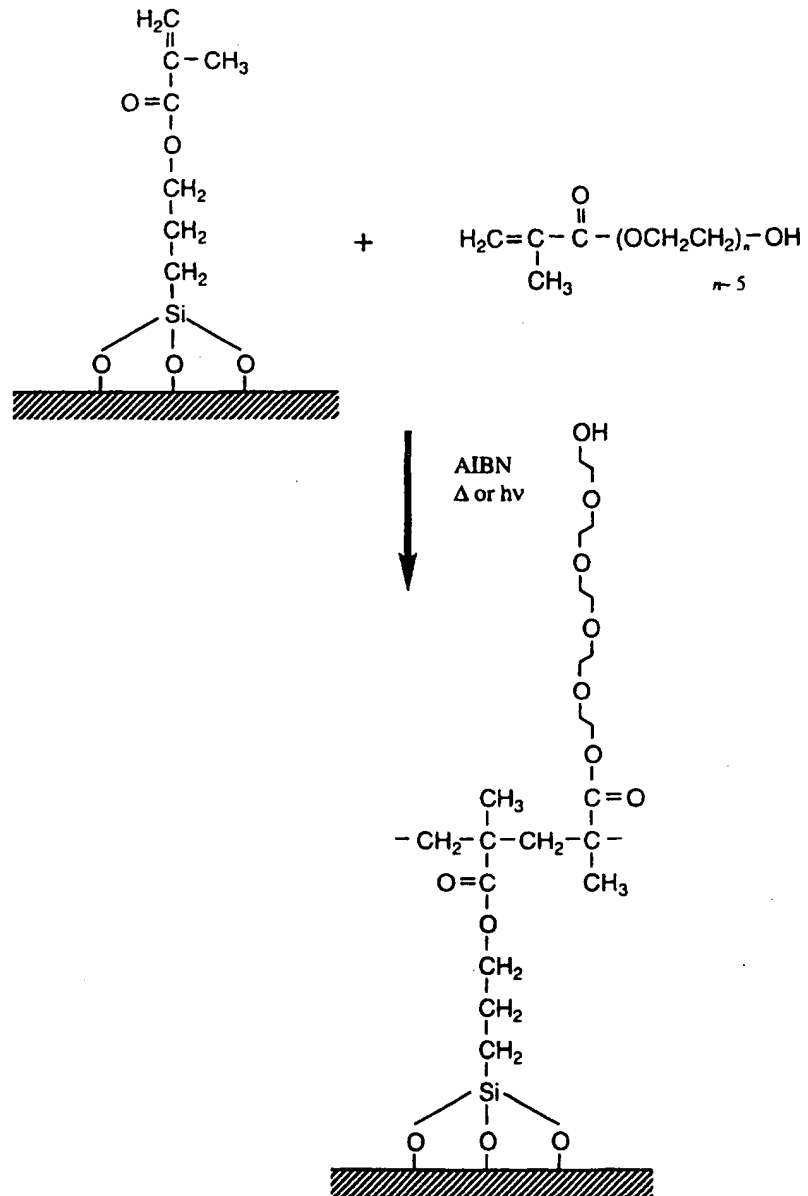


FIG. 31

32/34



**FIG. 32**

SUBSTITUTE SHEET (RULE 26)



33/34

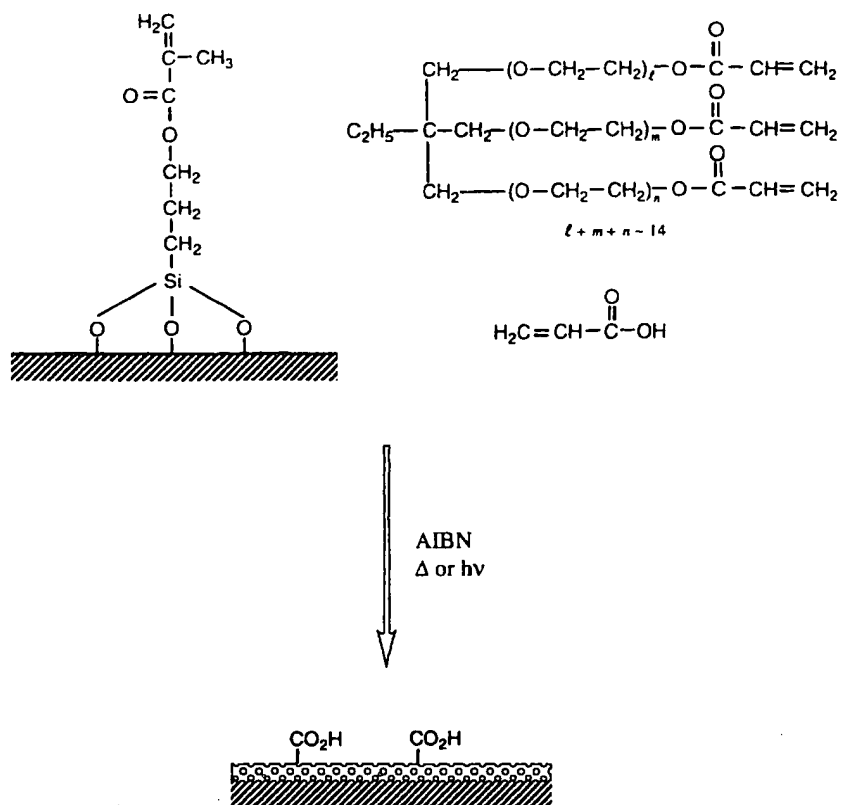


FIG. 33

34/34

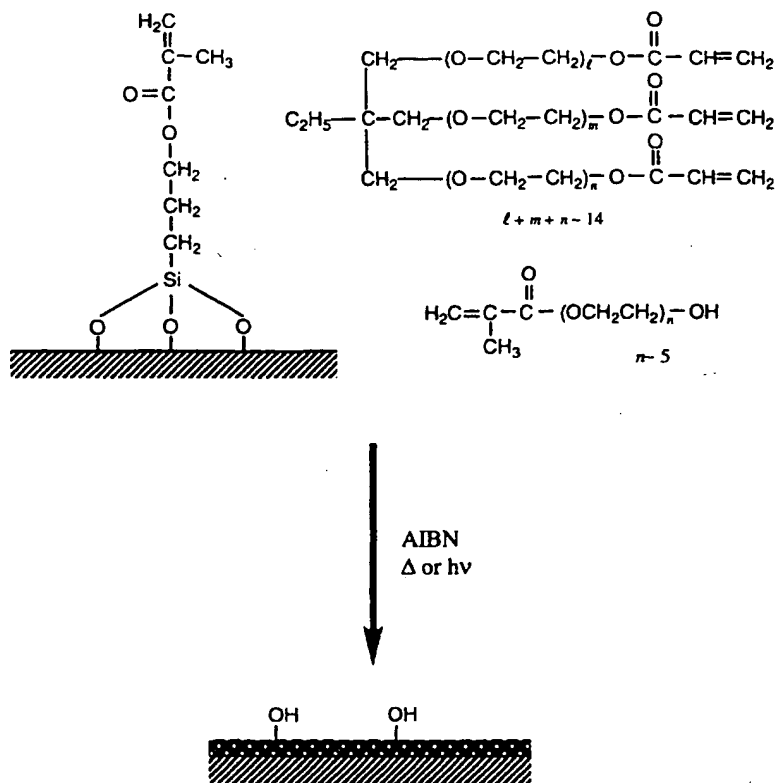


FIG. 34